



$V_{RRM}$	=	1200	V
$I_F (T_C \leq 135^\circ C)$	=	39	A**
$Q_C$	=	86	nC**

### Features

- Zero Reverse Recovery Current
- Zero Forward Recovery Voltage
- Positive Temperature Coefficient on  $V_F$
- Temperature-independent Switching
- 175°C Operating Junction Temperature
- Lead Free Package and Finish

### Benefits

- Replace Bipolar with Unipolar Device
- Reduction of Heat Sink Size
- Parallel Devices Without Thermal Runaway
- Essentially No Switching Losses

### Applications

- Switch Mode Power Supplies
- Power Factor Correction
- Motor drive, PV Inverter, Wind Power Station

### TO-247-3

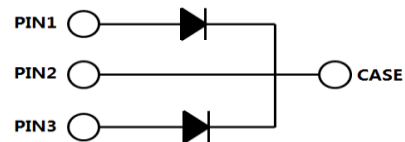
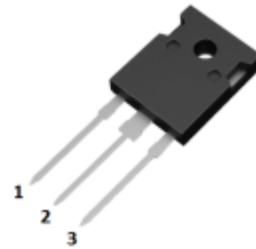

Part Number	Package	Marking
LGE3D30120D	TO-247-3	LGE3D30120D

### Maximum Ratings

Symbol	Parameter	Value	Unit	Test Conditions	Note
$V_{RRM}$	Repetitive Peak Reverse Voltage	1200	V	$T_C = 25^\circ C$	
$V_{RSM}$	Surge Peak Reverse Voltage	1200	V	$T_C = 25^\circ C$	
$V_R$	DC Blocking Voltage	1200	V	$T_C = 25^\circ C$	
$I_F$	Forward Current (Per leg/Device)	42/84 19.5/39 15/30	A	$T_C \leq 25^\circ C$ $T_C \leq 135^\circ C$ $T_C \leq 150^\circ C$	
$I_{FSM}$	Non-Repetitive Forward Surge Current	137*	A	$T_C = 25^\circ C, t_p = 8.3ms, \text{Half Sine Wave}$	
$P_{tot}$	Power Dissipation (Per leg/Device)	214/ 428	W	$T_C = 25^\circ C$	Fig.3
$T_C$	Maximum Case Temperature	150	$^\circ C$		
$T_J, T_{STG}$	Operating Junction and Storage Temperature	-55 to 175	$^\circ C$		
	TO-247 Mounting Torque	1	Nm	M3 Screw	

\*Per Leg, \*\*Per Device

## Electrical Characteristics (Per Leg)

Symbol	Parameter	Typ.	Max.	Unit	Test Conditions	Note
$V_F$	Forward Voltage	1.55 2.2	1.8 2.5	V	$I_F = 15A, T_J = 25^\circ C$ $I_F = 15A, T_J = 175^\circ C$	Fig.1
$I_R$	Reverse Current	5 20	20 200	$\mu A$	$V_R = 1200V, T_J = 25^\circ C$ $V_R = 1200V, T_J = 175^\circ C$	Fig.2
C	Total Capacitance	940 70 57	/	pF	$V_R = 0V, T_J = 25^\circ C, f = 1MHz$ $V_R = 400V, T_J = 25^\circ C, f = 1MHz$ $V_R = 800V, T_J = 25^\circ C, f = 1MHz$	Fig.5
$Q_C$	Total Capacitive Charge	43	/	nC	$V_R = 800V, I_F = 15A$ $di/dt = 200A/\mu s, T_J = 25^\circ C$	Fig.4

## Thermal Characteristics

Symbol	Parameter	Typ.	Unit	Note
$R_{\theta JC}$	Thermal Resistance from Junction to Case	0.7* 0.35**	$^\circ C/W$	Fig.6
$R_{\theta JA}$	Thermal Resistance from Junction to Ambient	80	$^\circ C/W$	
$T_{sold}$	Soldering Temperature	260	$^\circ C$	

\*Per Leg, \*\*Per Device

## Typical Performance

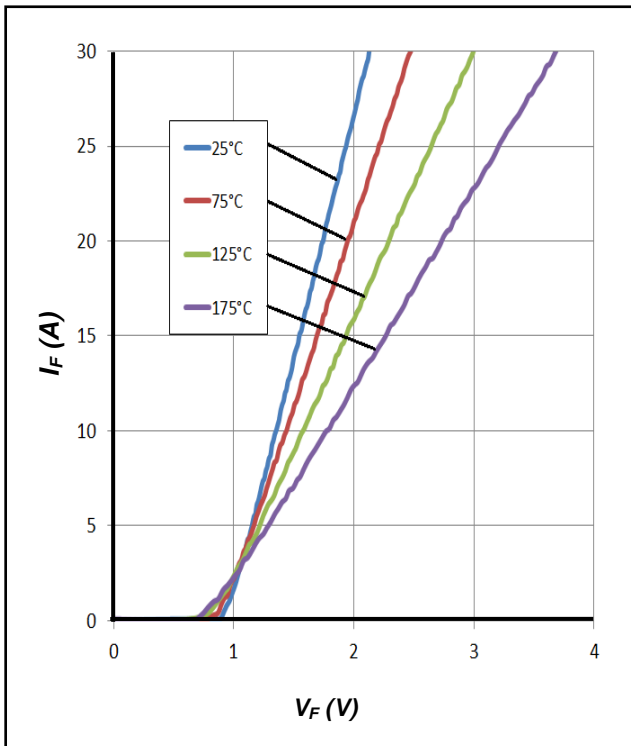

Figure 1. Forward Characteristics

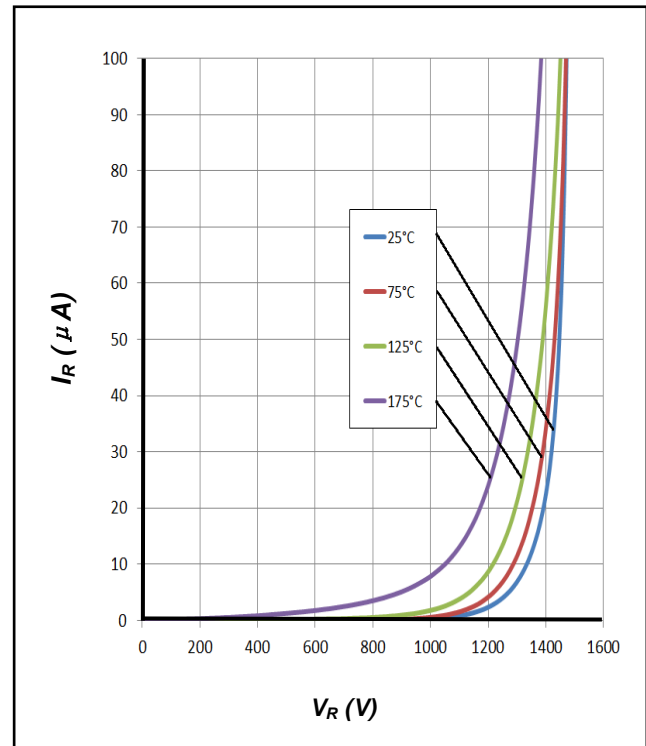

Figure 2. Reverse Characteristics



### Typical Performance

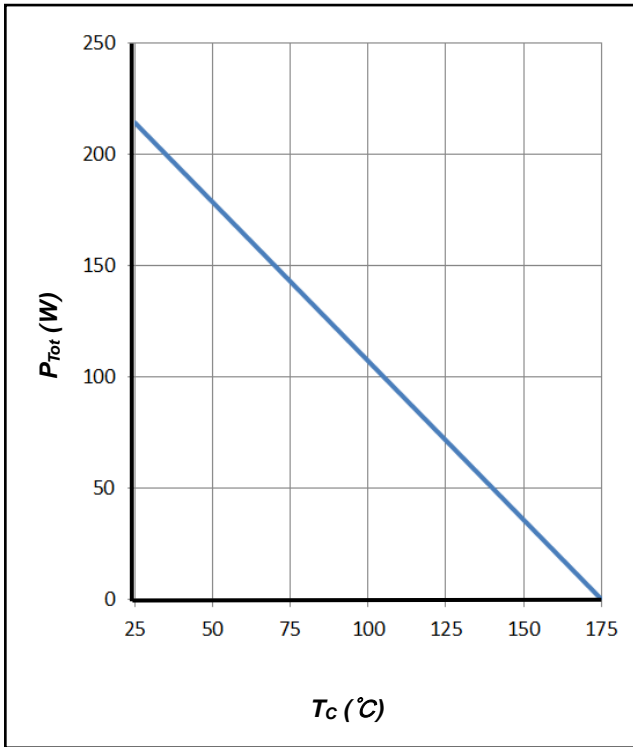

Figure 3. Power Derating

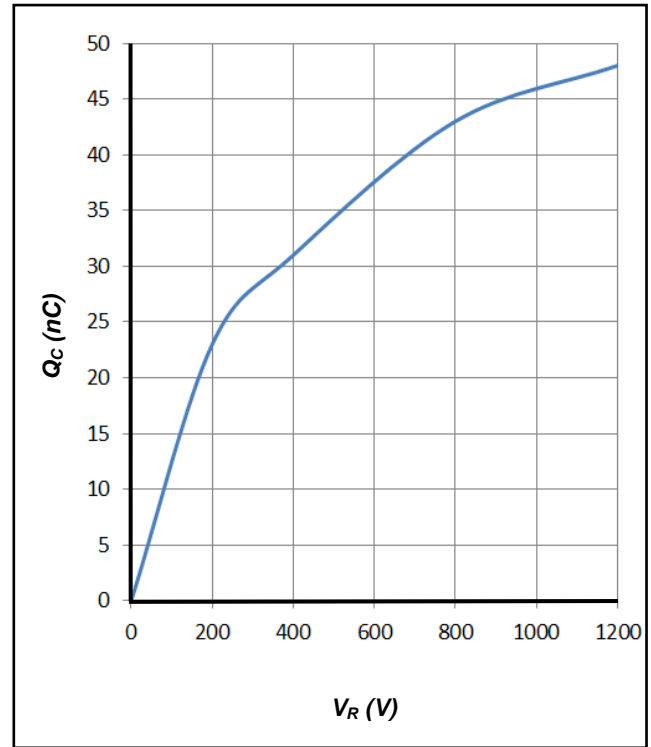

Figure 4. Total Capacitive Charge vs. Reverse Voltage

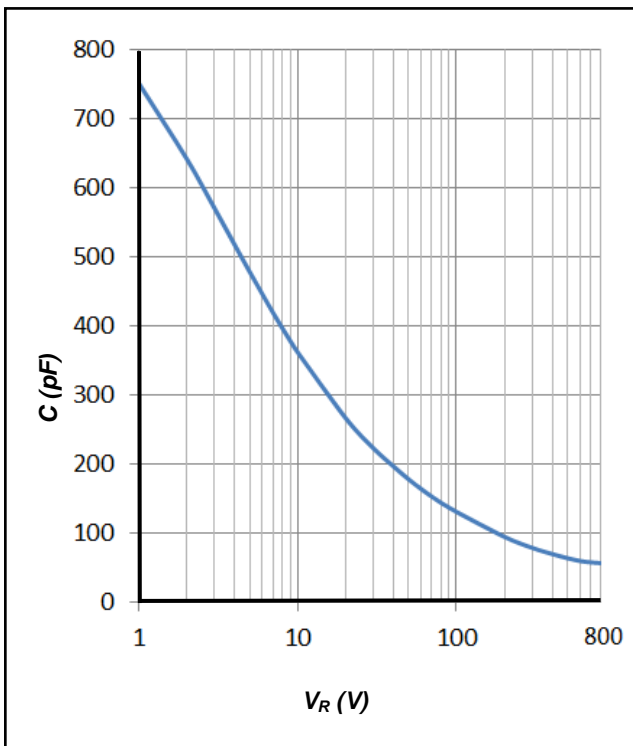

Figure 5. Total Capacitance vs. Reverse Voltage

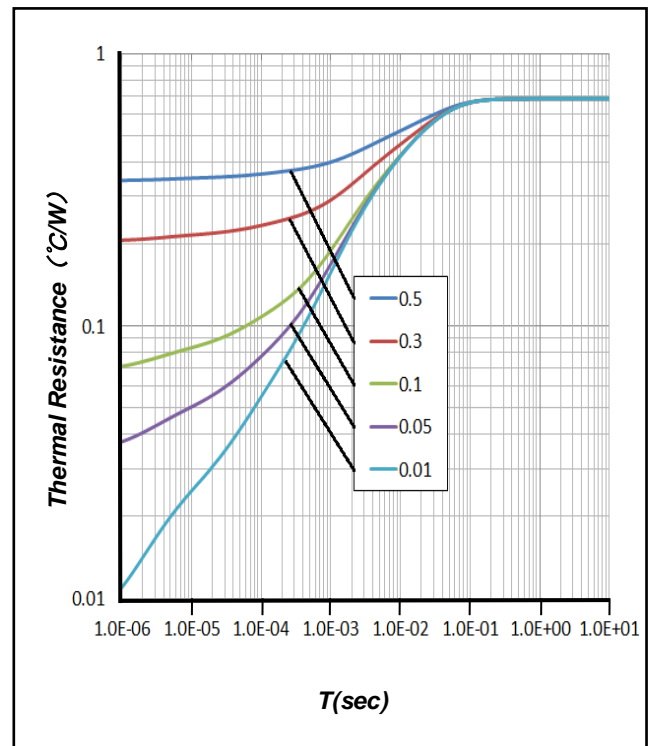
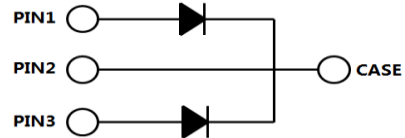
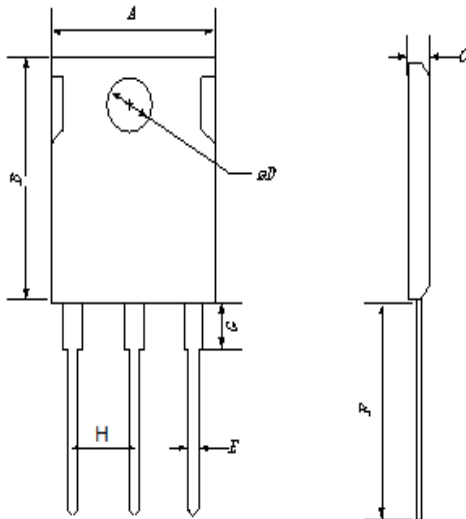

Figure 6. Transient Thermal Impedance



### Package Dimensions

Package TO-247-3



Symbol	Min. (mm)	Typ. (mm)	Max. (mm)
A	14.18	15.75	17.33
B	18.45	20.5	22.55
C	4.50	5.00	5.50
D	3.15	3.50	3.85
E	1.08	1.20	1.32
F	18.27	20.30	22.33
G	4.21	4.68	5.15
H	4.91	5.46	6.01

### Simplified Diode Model

Equivalent IV Curve for Model

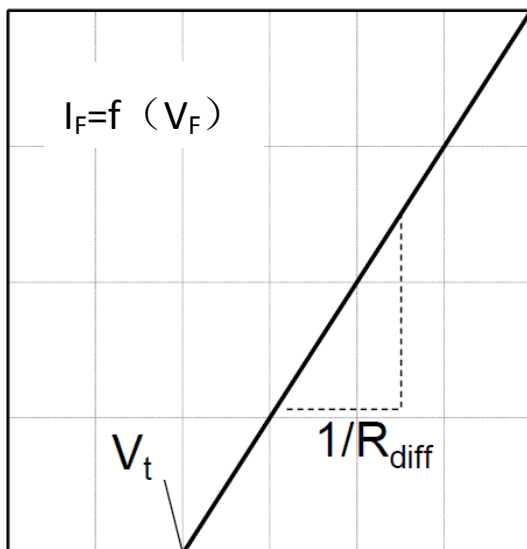

Mathematical Equation(Per Leg)

$$V_F = V_t + I_F \times R_{diff}$$

$$V_t = -0.001 \times T_j + 0.9836 \quad [V]$$

$$R_{diff} = 1 \times 10^{-6} \times T_j^2 + 1 \times 10^{-4} \times T_j + 0.0347 \quad [\Omega]$$

Note:

$T_j$  = Diode Junction Temperature In Degrees Celsius,  
valid from 25°C to 175°C

$I_F$  = Forward Current

Less than 30A

Package	Packing	Box Size LxWxH(mm)	Quantity(pcs/box)	Carton Size LxWxH(mm)	Quantity(pcs/carton)
TO-247	30pcs/Tube	570x155x50	450	580x340x125	1800