

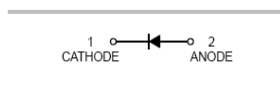

Features

- High switching speed
- Continuous reverse voltage
- Repetitive peak reverse voltage
- Repetitive peak forward current



Typical Applications

- High-speed switching in surface mounted circuits

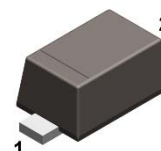

Mechanical Data

- Case: SOD-523
- Molding Compound: UL Flammability Classification Rating 94V-0
- Terminals: Matte tin-plated leads; solderability-per MIL-STD-202, Method 208

SOD-523

Ordering Information

Part Number	Package	Shipping Quantity	Marking Code
BAS516	SOD-523	3000 pcs / Tape & Reel	61

Maximum Ratings (@ T_A = 25 °C unless otherwise specified)

Parameter	Symbol	Value	Unit
Peak Repetitive Peak Reverse Voltage	V _{RRM}	100	V
DC Blocking Voltage	V _R		
Continuous Forward Current	I _F	250	mA
Repetitive Forward Current	I _{FRM}	500	mA
Peak Forward Surge Current, t _p = 1μs	I _{FSM}	4	A
Peak Forward Surge Current, t _p = 1ms	I _{FSM}	1	A
Peak Forward Surge Current, t _p = 1s	I _{FSM}	0.5	A

Thermal Characteristics

Parameter	Symbol	Value	Unit
Power Dissipation	P _D	200	mW
Thermal Resistance Junction-to-Air *1	R _{θJA}	458	°C/W
Thermal Resistance Junction-to-Case *1	R _{θJC}	286	°C/W
Thermal Resistance Junction-to-Lead *1	R _{θJL}	324	°C/W
Operating Junction Temperature Range	T _J	-65 ~ +150	°C
Storage Temperature Range	T _{STG}	-65 ~ +150	°C

Electrical Characteristics (@ $T_A = 25\text{ }^\circ\text{C}$ unless otherwise specified)

Parameter	Symbol	Test Condition	Min.	Typ.		Unit
Forward Voltage	V_F	$I_F = 1.0\text{mA}$	-	-	0.715	V
		$I_F = 10\text{mA}$	-	-	0.855	
		$I_F = 50\text{mA}$	-	-	1.0	
		$I_F = 150\text{mA}$	-	-	1.25	
Maximum Peak Reverse Current	I_R	$V_R = 25\text{V}, T_J = 25^\circ\text{C}$	-	-	30	nA
		$V_R = 25\text{V}, T_J = 125^\circ\text{C}$	-	-	30	μA
		$V_R = 75\text{V}, T_J = 25^\circ\text{C}$	-	-	1	
		$V_R = 75\text{V}, T_J = 150^\circ\text{C}$	-	-	50	
Total Capacitance	C_J	$V_R = 0\text{V}, f = 1.0\text{MHz}$	-	-	1	pF
Reverse Recovery Time	t_{rr}	$I_F = I_R = 10\text{mA}, R_L = 400\Omega$	-	-	4	ns

Note 1: The data tested by surface mounted on a 15mm * 15mm * 1mm FR4-epoxy P.C.B

Ratings and Characteristic Curves (@ $T_A = 25^\circ\text{C}$ unless otherwise specified)

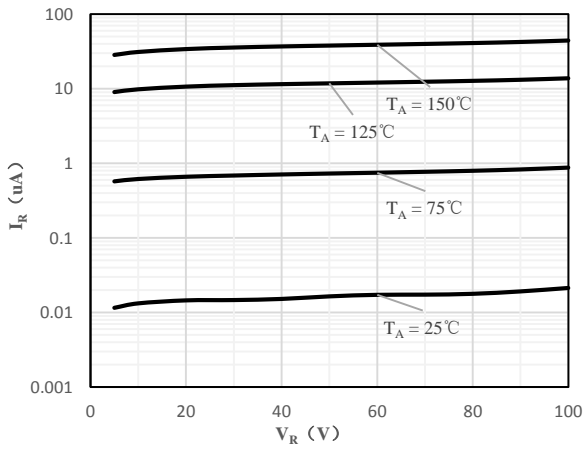

Fig 1 Typical Reverse Characteristic

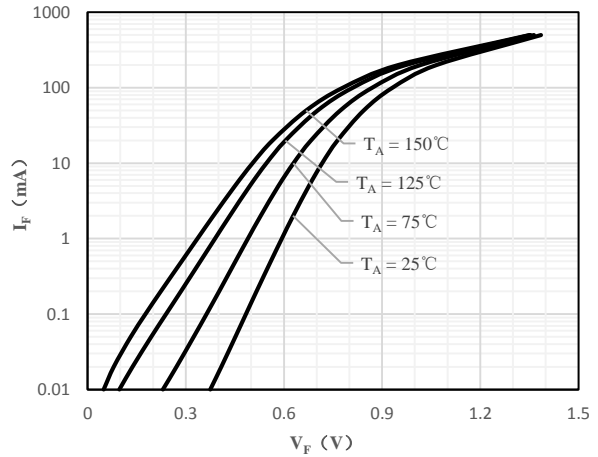

Fig 2 Typical Forward Characteristic

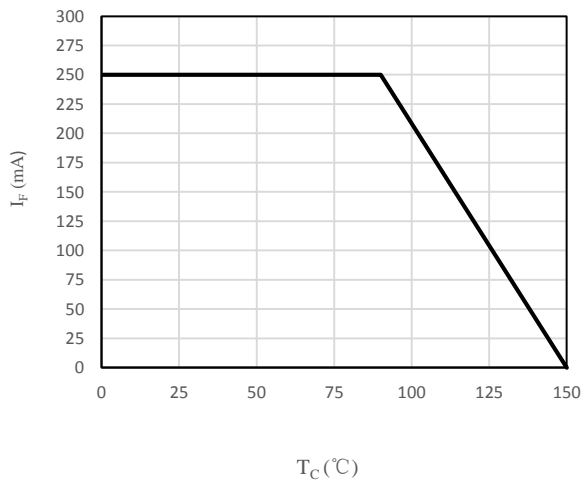

Fig 3 Current Derating Curve

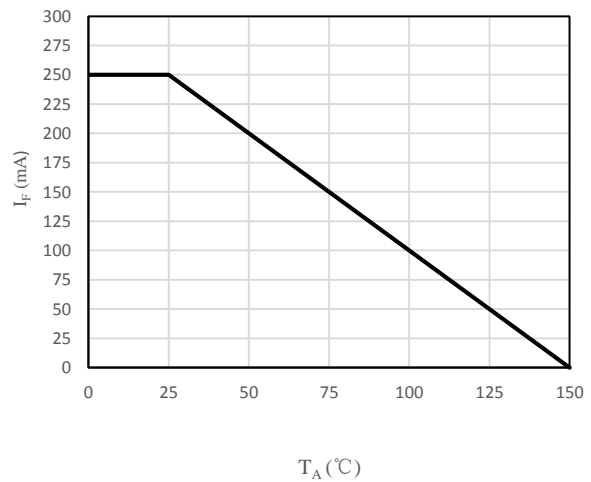

Fig 4 Current Derating Curve

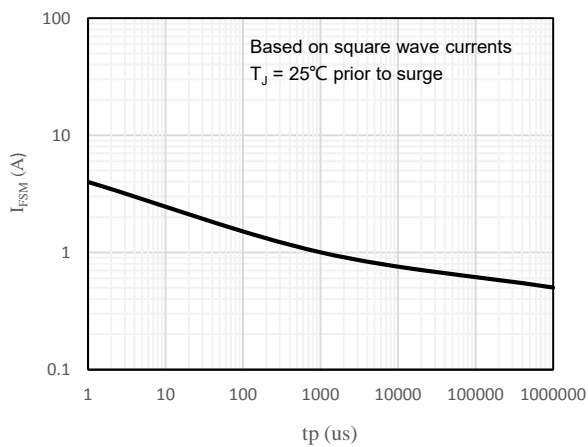

Fig 5 Non-repetitive peak forward current as a function of pulse duration; maximum values

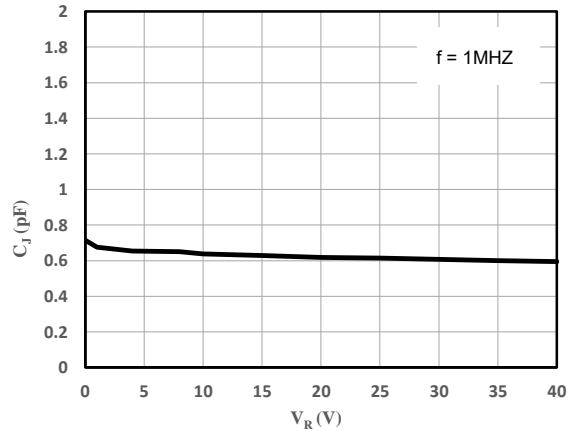
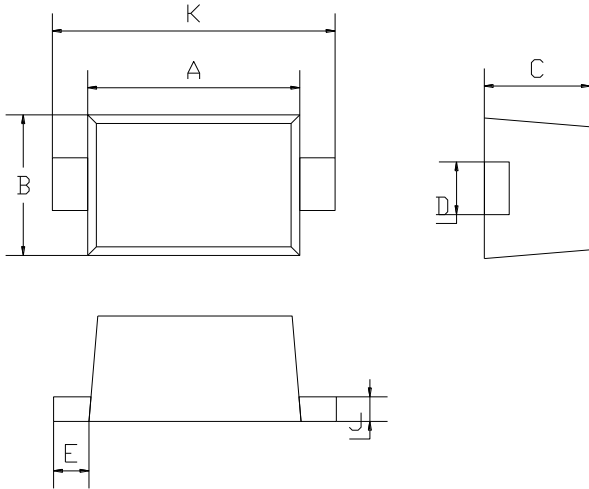

Fig 6 Diode capacitance as a function of reverse voltage; typical values

Package Outline Dimensions (Unit: mm)



SOD-523		
Dimension	Min.	Max.
A	1.10	1.30
B	0.70	0.90
C	0.50	0.70
D	0.25	0.35
E	0.15	0.25
J	0.05	0.15
K	1.50	1.70

Mounting Pad Layout (Unit: mm)

SOD-523

