

FEATURES

- Darlington Transistor

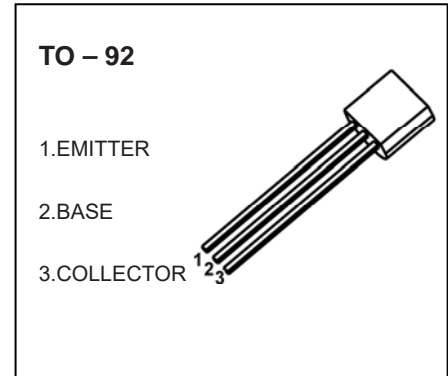

MARKING

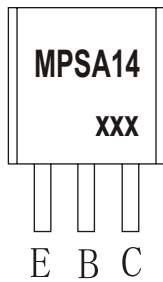

MPSA14=Device code
XXX=Code
GXX=Green molding compound device
CXX=Normal molding compound device

Equivalent Circuit

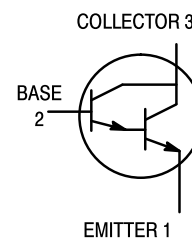

ORDERING INFORMATION

Part Number	Package	Packing Method	Pack Quantity
MPSA14	TO-92	Bulk	1000pcs/Bag
MPSA14-TA	TO-92	Tape	2000pcs/Box

MAXIMUM RATINGS (T_a=25°C unless otherwise noted)

Symbol	Parameter	Value	Unit
V _{CB0}	Collector-Base Voltage	30	V
V _{CEO}	Collector-Emitter Voltage	30	V
V _{EBO}	Emitter-Base Voltage	10	V
I _c	Collector Current -Continuous	0.5	A
P _D	Collector Power Dissipation	625	mW
R _{θJA}	Thermal Resistance from Junction to Ambient	200	°C /W
T _J , T _{stg}	Operation Junction and Storage Temperature Range	-55~+150	°C



ELECTRICAL CHARACTERISTICS($T_a=25^\circ\text{C}$ unless otherwise specified)

Parameter	Symbol	Test conditions	Min	Typ	Max	Unit
Collector-base breakdown voltage	$V_{(BR)CBO}$	$I_C = 0.1\text{mA}, I_E = 0$	30			V
Collector-emitter breakdown voltage	$V_{(BR)CEO}$	$I_C = 1\text{mA}, I_B = 0$	30			V
Emitter-base breakdown voltage	$V_{(BR)EBO}$	$I_E = 0.1\text{mA}, I_C = 0$	10			V
Collector cut-off current	I_{CBO}	$V_{CB} = 30\text{V}, I_E = 0$			0.1	KA
Emitter cut-off current	I_{EBO}	$V_{EB} = 10\text{V}, I_C = 0$			0.1	KA
DC current gain	$h_{FE(1)}^*$	$V_{CE} = 5\text{V}, I_C = 10\text{mA}$	10000			
	$h_{FE(2)}^*$	$V_{CE} = 5\text{V}, I_C = 100\text{mA}$	20000			
Collector-emitter saturation voltage	$V_{CE(sat)}^*$	$I_C = 100\text{mA}, I_B = 0.1\text{mA}$			1.5	V
Base-emitter voltage	V_{BE}^*	$V_{CE} = 5\text{V}, I_C = 100\text{mA}$			2.0	V
Transition frequency	f_T	$V_{CE} = 5\text{V}, I_C = 10\text{mA}, f = 100\text{MHz}$	125			MHz

*Pulse test: pulse width $\leq 300\mu\text{s}$, duty cycle $\leq 2.0\%$.



Typical Characteristics

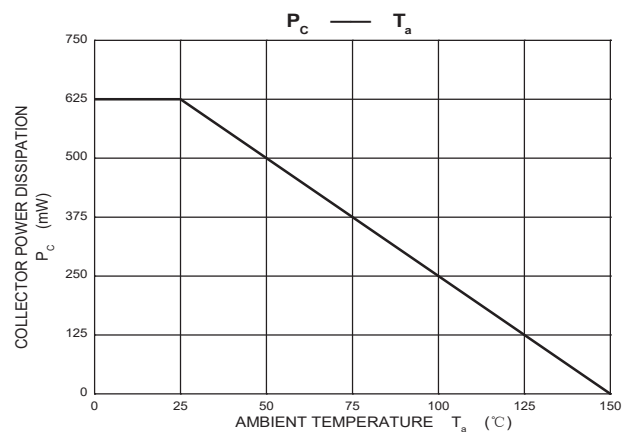
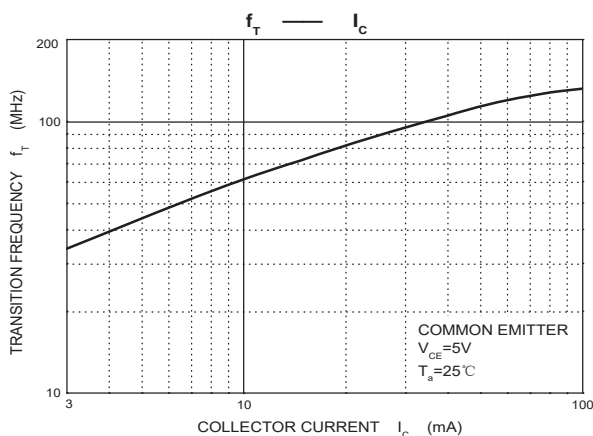
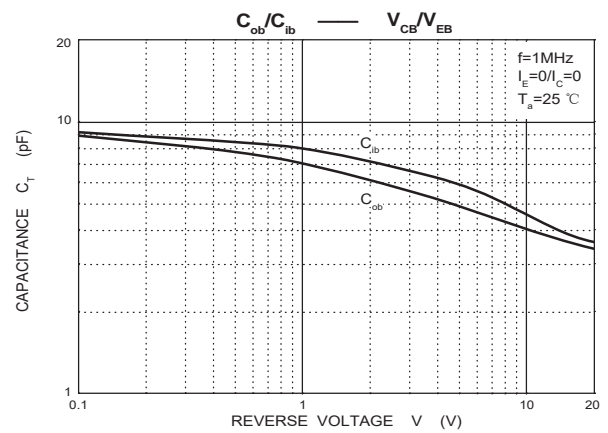
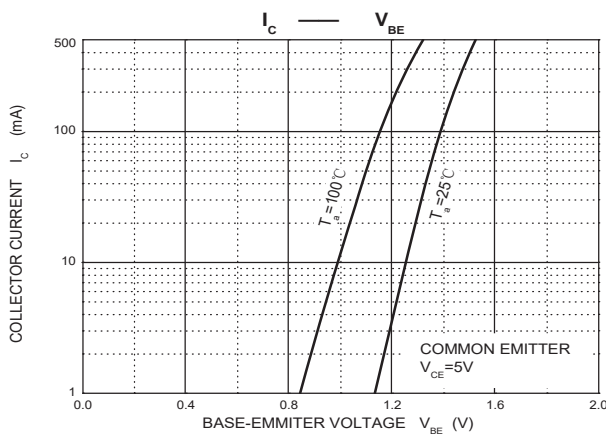
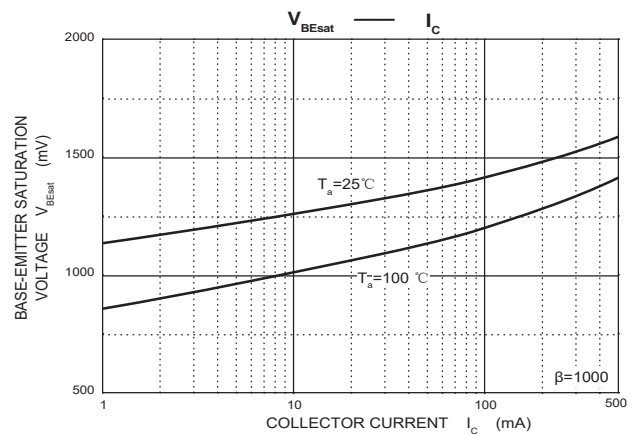
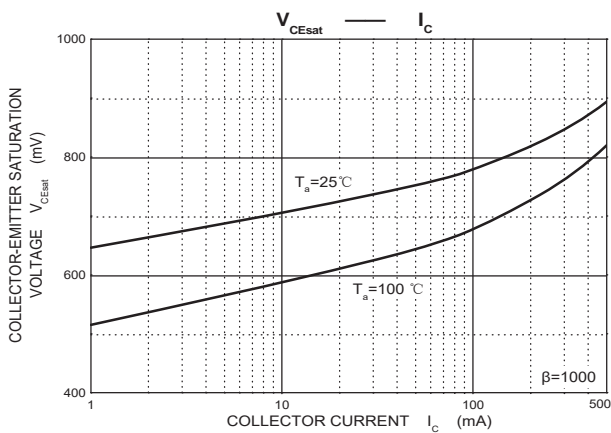
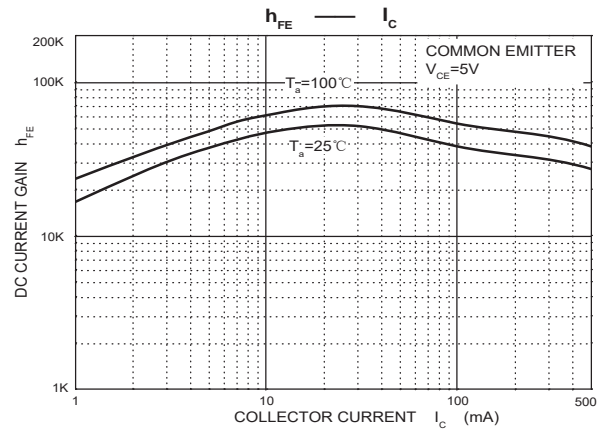
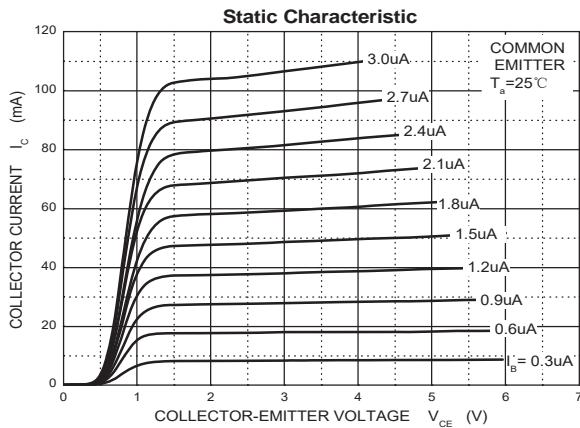



TO-92 Package Outline Dimensions

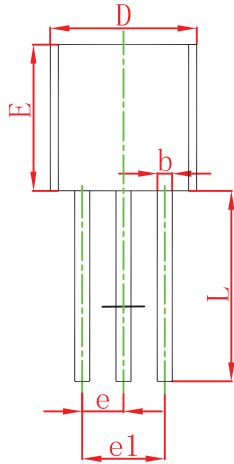
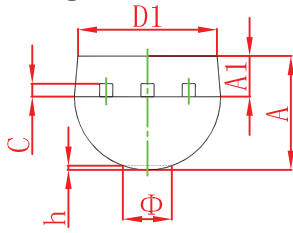

Symbol	Dimensions In Millimeters		Dimensions In Inches	
	Min	Max	Min	Max
A	3.300	3.700	0.130	0.146
A1	1.100	1.400	0.043	0.055
b	0.380	0.550	0.015	0.022
c	0.360	0.510	0.014	0.020
D	4.300	4.700	0.169	0.185
D1	3.430		0.135	
E	4.300	4.700	0.169	0.185
e	1.270 TYP		0.050 TYP	
e1	2.440	2.640	0.096	0.104
L	14.100	14.500	0.555	0.571
K		1.600		0.063
h	0.000	0.380	0.000	0.015

TO-92 Suggested Pad Layout

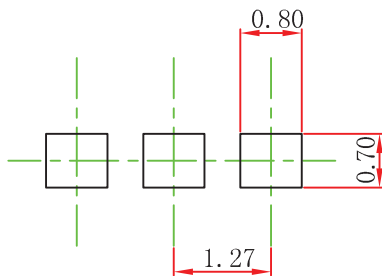

Note:

1. Controlling dimension: in millimeters.
2. General tolerance: $\pm 0.05\text{mm}$.
3. The pad layout is for reference purposes only.

TO-92 Tape and Reel

TO-92 PACKAGE TAPEING DIMENSION

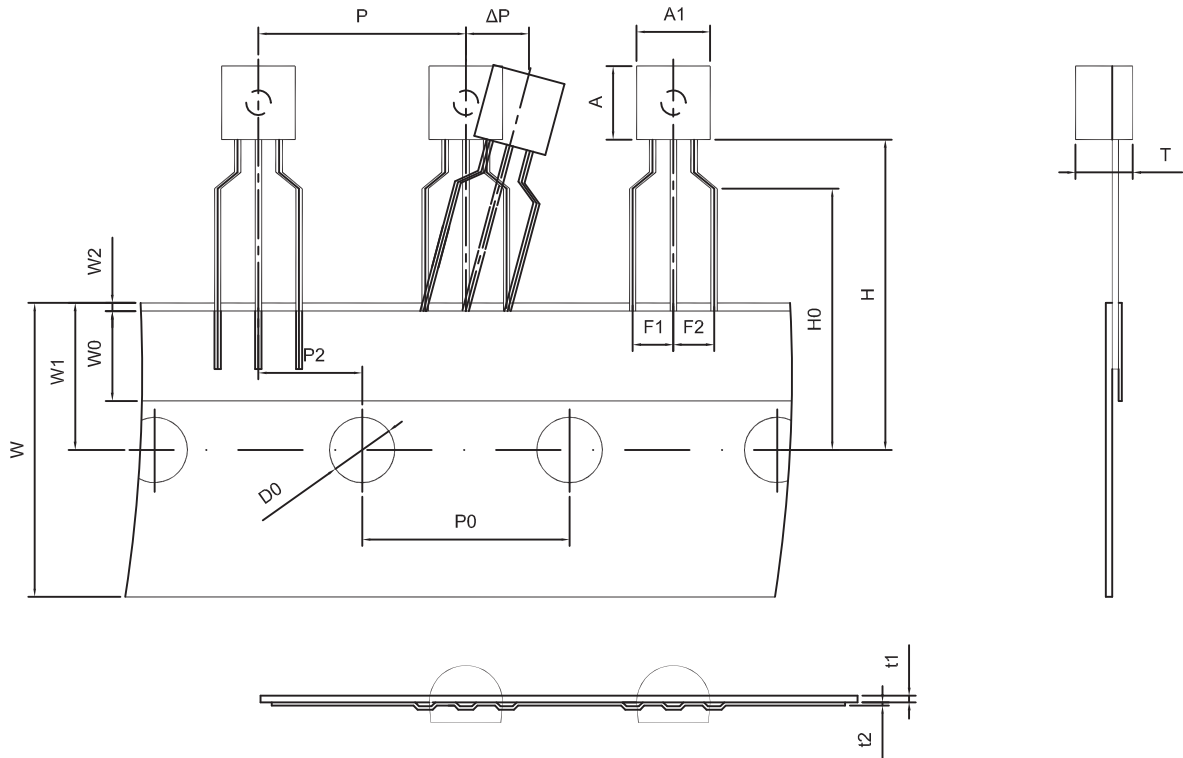

Dimiensions are in millimeter								
A1	A	T	P	P0	P2	F1	F2	W
4.5	4.5	3.5	12.7	12.7	6.35	2.5	2.5	18.0
W0	W1	W2	H	H0	D0	t1	t2	ΔP
6.0	9.0	1.0 MAX.	19.0	16.0	4.0	0.4	0.2	0

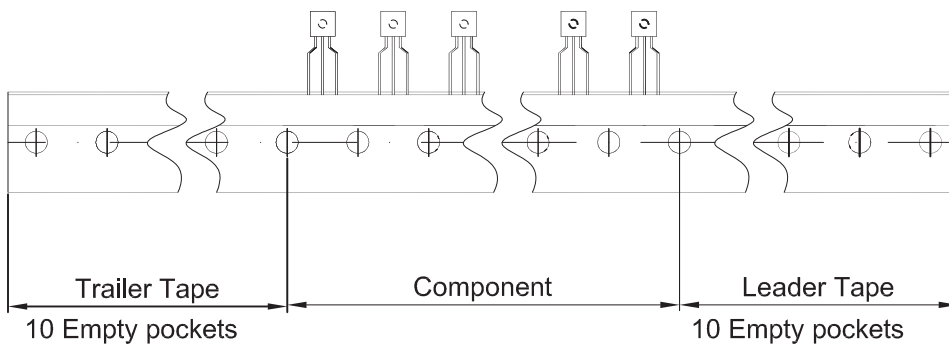

Package	Box	Box Size(mm)	Carton	Carton Size(mm)
TO-92	2000 pcs	333×162×43	20,000 pcs	350×340×250