



FEATURES

- Epitaxial planar die construction.
- Complementary PNP type available (MMBTA63-3L/MMBTA64-3L).
- High current gain.
- MSL 1

APPLICATIONS

- Ideal for medium power amplification and switching.

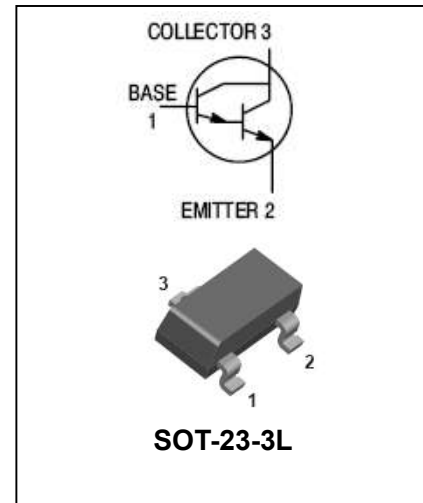

ORDERING INFORMATION

Type No.	Marking	Package Code
MMBTA13□-3L	K2D	SOT-23-3L

□: none is for Lead Free package;

“G” is for Halogen Free package.

MAXIMUM RATING @ Ta=25°C unless otherwise specified

Symbol	Parameter	Value	UNIT
V _{CBO}	collector-base voltage	30	V
V _{CEO}	collector-emitter voltage	30	V
V _{EBO}	emitter-base voltage	10	V
I _C	collector current (DC)	0.3	A
P _C	Collector dissipation	0.3	W
R _{θJA}	Thermal Resistance, Junction to Ambient	417	°C/W
T _j , T _{stg}	junction and storage temperature	-55 to +150	°C

ELECTRICAL CHARACTERISTICS @ Ta=25°C unless otherwise specified

Symbol	Parameter	Test conditions	MIN.	MAX.	UNIT
$V_{(BR)CBO}$	Collector-base breakdown voltage MMBTA13-3L	$I_C=100\mu A, I_E=0$	30	-	V
$V_{(BR)CEO}$	Collector-emitter breakdown voltage MMBTA13-3L	$I_C=0.1mA, I_B=0$	30	-	V
$V_{(BR)EBO}$	Emitter-base breakdown voltage	$I_E=100\mu A, I_C=0$	10	-	V
I_{CBO}	collector cut-off current	$I_E = 0; V_{CB} = 30V$	-	0.1	μA
I_{CEO}	collector cut-off current	$I_E = 0; V_{CE} = 10V$	-	0.1	μA
h_{FE}	DC current gain MMBTA13-3L MMBTA13-3L	$V_{CE} = 5V; I_C = 10mA$ $V_{CE} = 5V; I_C = 100mA$	5000 10000	-	
$V_{CE(sat)}$	collector-emitter saturation voltage	$I_C = 100mA; I_B = 0.1mA$	-	1.5	V
V_{BE}	Base-emitter on voltage	$I_C=100mA, V_{CE}=5V$	-	2.0	V
f_T	transition frequency	$I_C = 10mA; V_{CE} = 5.0V;$ $f = 100MHz$	125	-	MHz

TYPICAL CHARACTERISTICS @ Ta=25°C unless otherwise specified

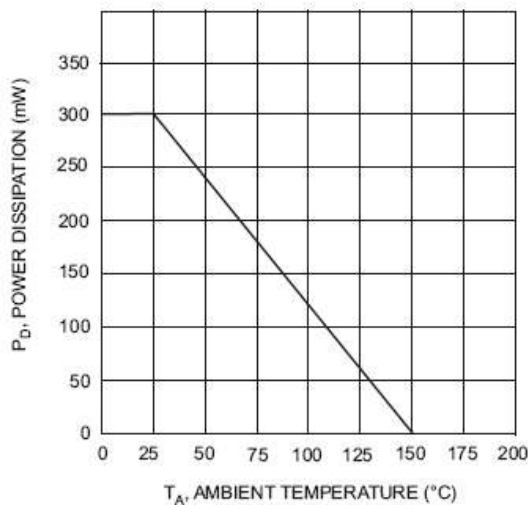

Fig. 1, Max Power Dissipation vs Ambient Temperature

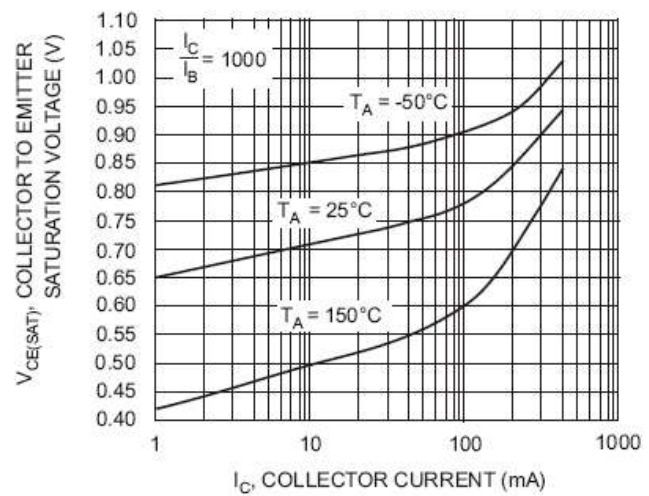

Fig. 2, Collector Emitter Saturation Voltage vs. Collector Current



PACKAGE OUTLINE

Plastic surface mounted package

SOT-23-3L

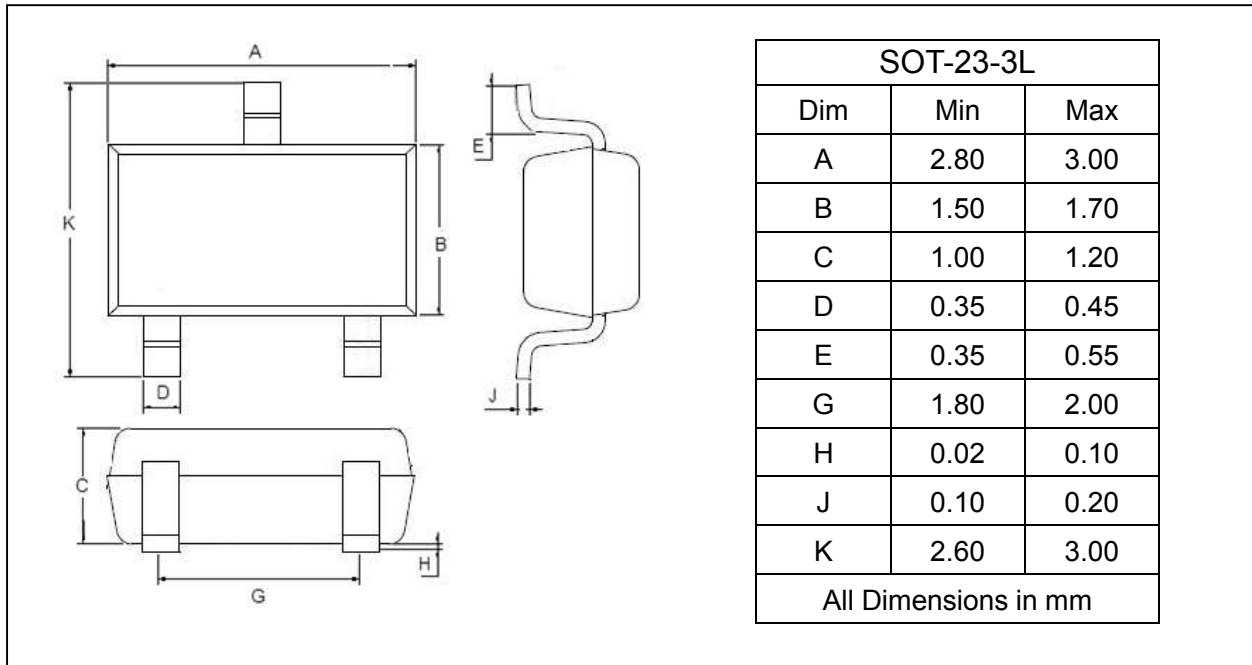

SOLDERING FOOTPRINT

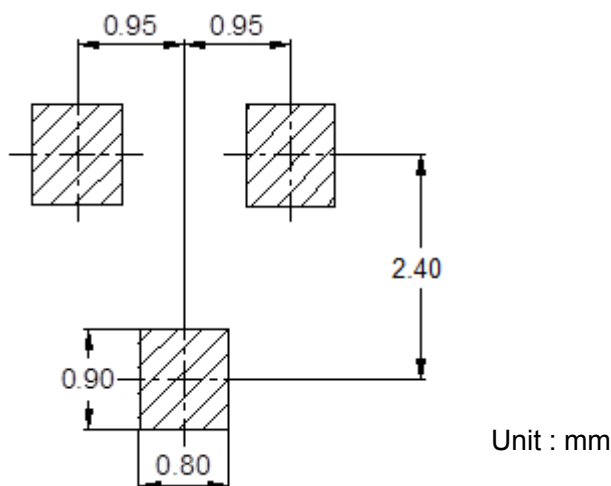

PACKAGE INFORMATION

Device	Package	Shipping
MMBTA13-3L	SOT-23-3L	3000/Tape&Reel