

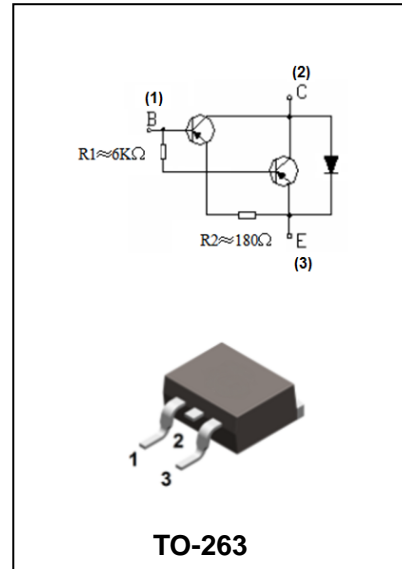

FEATURES

- Complementary to TIP122-B



Ordering Information

Part Number	Package	Shipping	Marking Code
TIP127-B	TO-263	50 pcs / Tube & 800 pcs / Tape & Reel	TIP127

MAXIMUM RATING operating temperature range applies unless otherwise specified

Symbol	Parameter	Value	Unit
V_{CBO}	Collector-Base Voltage	-100	V
V_{CEO}	Collector-Emitter Voltage	-100	V
V_{EBO}	Emitter-Base Voltage	-5	V
I_C	Collector Current	DC Pulse	A
I_B	Base Current	-120	mA
P_C	Collector Dissipation	$T_a=25^\circ\text{C}$ $T_C=25^\circ\text{C}$	W
T_j, T_{stg}	Junction and Storage Temperature	-65 to +150	$^\circ\text{C}$



ELECTRICAL CHARACTERISTICS Ratings at 25°C ambient temperature unless otherwise specified.

Parameter	Symbol	Test conditions	MIN	TYP	MAX	UNIT
Collector-emitter Sustaining Voltage	$V_{CEO(SUS)}$	$I_C=100mA, I_B=0$	-100			V
Collector Cut-off Current	I_{CEO}	$V_{CE}=50V, I_B=0$			-0.5	mA
Collector Cut-off Current	I_{CBO}	$V_{CB}=100V, I_E=0$			-0.2	mA
Emitter Cut-off Current	I_{EBO}	$V_{EB}=5V, I_C=0$			-2	mA
DC Current Gain	h_{FE}	$V_{CE}=3V, I_C=0.5A$ $V_{CE}=3V, I_C=3A$	1000 1000			
Collector-emitter Saturation Voltage	$V_{CE(sat)}$	$I_C=3A, I_B=12mA$ $I_C=5A, I_B=20mA$			-2.0 -4.0	V
Base-emitter on Voltage	$V_{BE(on)}$	$V_{CE}=3V, I_C=3A$			-2.5	V
Output Capacitance	C_{ob}	$V_{CB}=10V, I_E=0,$ $f=0.1MHz$			200	pF



TYPICAL CHARACTERISTICS @ Ta=25°C unless otherwise specified

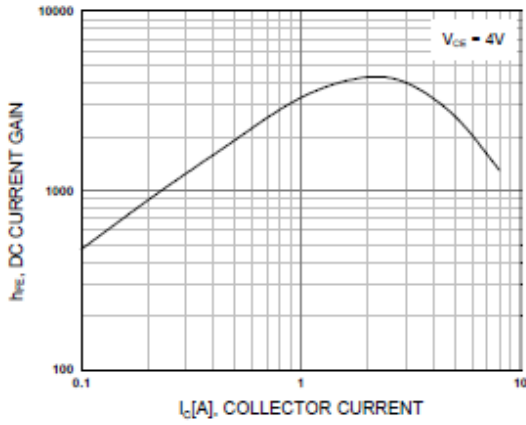

Figure 1. DC current Gain

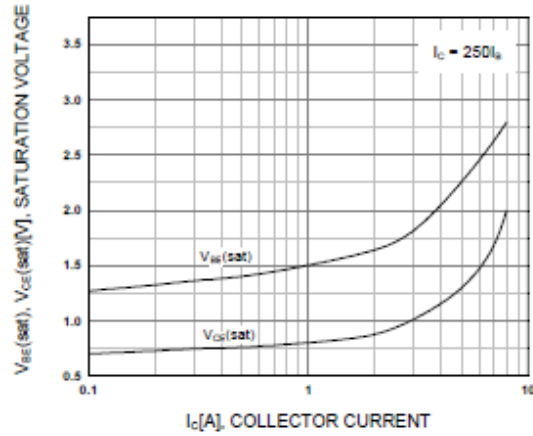

Figure 2. Base-Emitter Saturation Voltage
Collector-Emitter Saturation Voltage

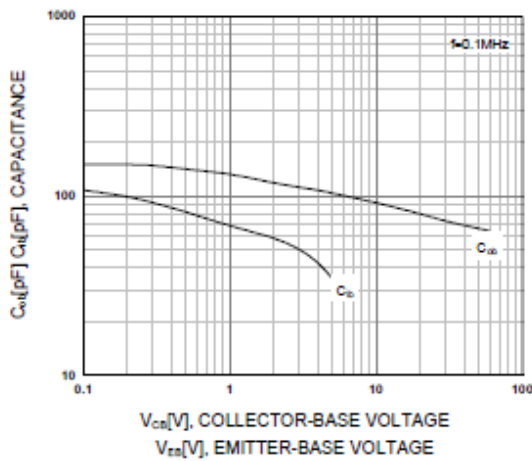

Figure 3. Output and Input Capacitance
vs. Reverse Voltage

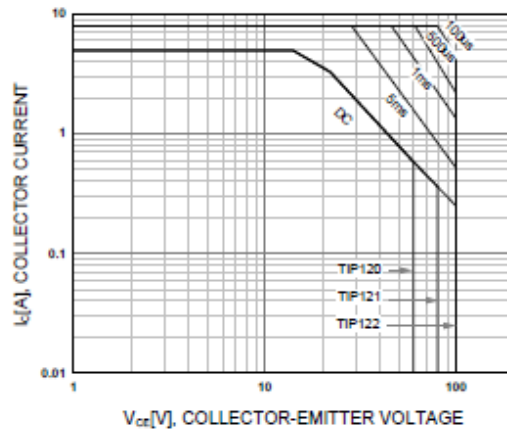

Figure 4. Safe Operating Area

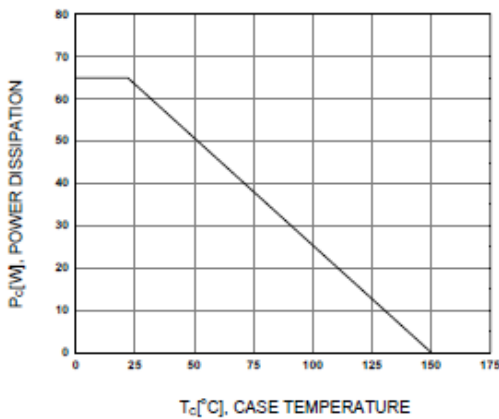

Figure 5. Power Derating



PACKAGE OUTLINE

Plastic surface mounted package

TO-263

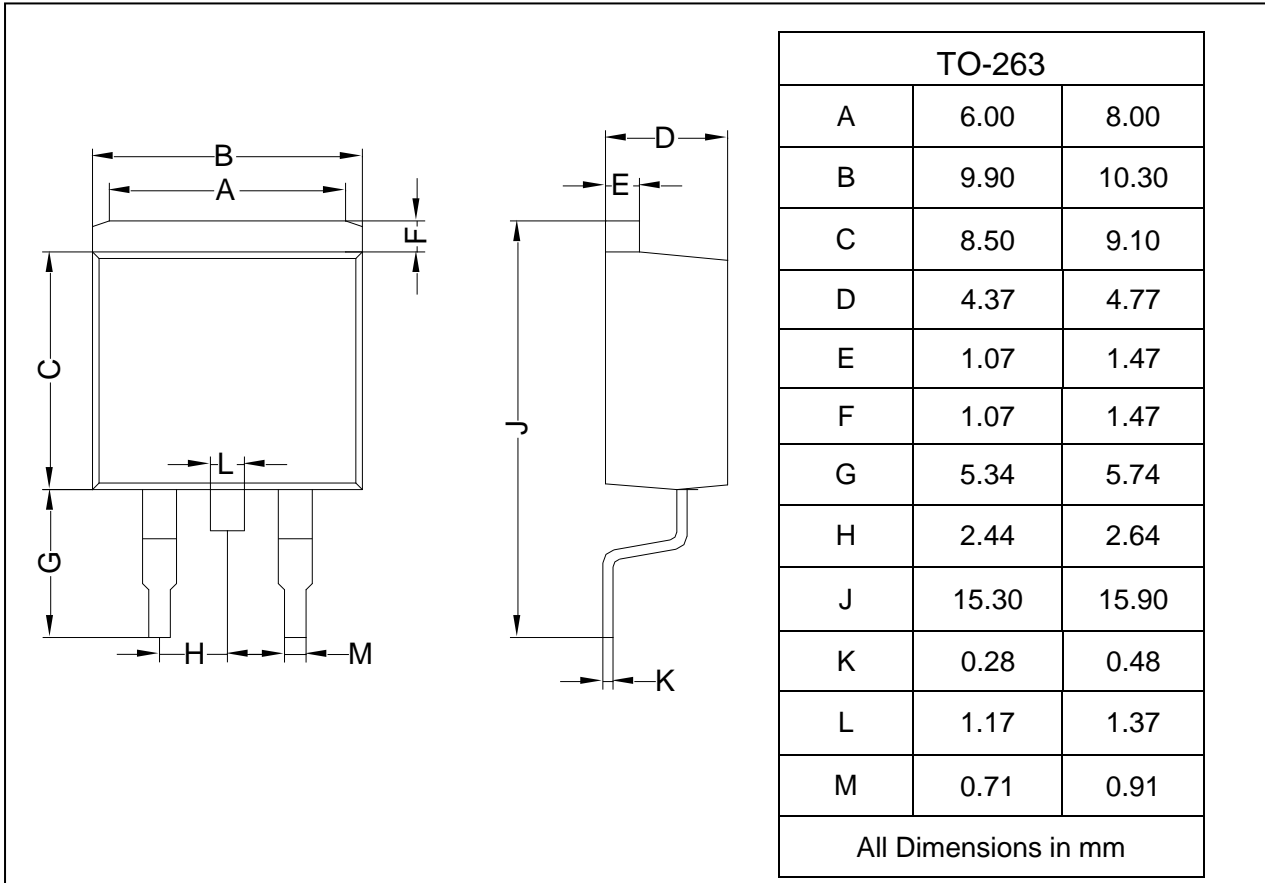

SOLDERING FOOTPRINT

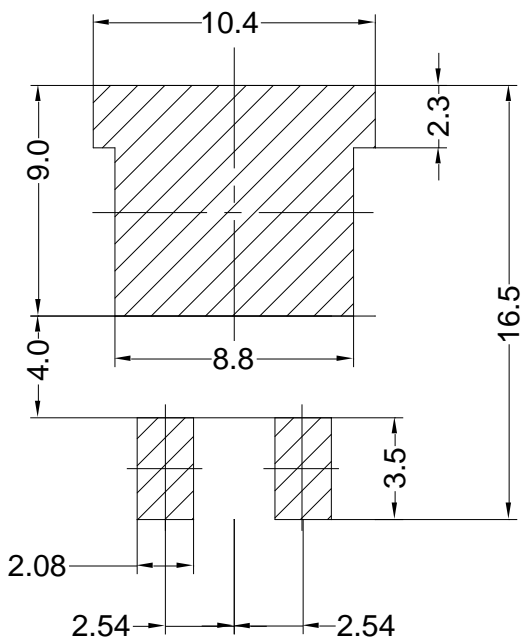

Unit: mm