



Features

- Epitaxial planar die construction
- Built-in biasing resistors ($R_1: 2.2k\Omega$, $R_2: 2.2k\Omega$)
- Also available in lead free version

Mechanical Data

- Case: SOT-23, SOT-323, SOT-523, DFN1006-3
- Molding Compound: UL Flammability Classification Rating 94V-0
- Terminals: Matte tin-plated leads; solderability-per

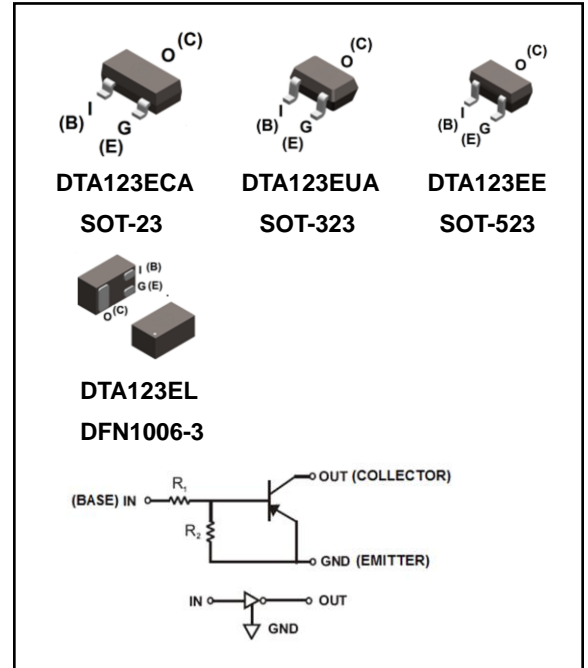

Ordering Information

Part Number	Package	Shipping Quantity	Marking Code
DTA123ECA	SOT-23	3000 pcs / Tape & Reel	12
DTA123EUA	SOT-323	3000 pcs / Tape & Reel	12
DTA123EE	SOT-523	3000 pcs / Tape & Reel	12
DTA123EL	DFN1006-3	10000 pcs / Tape & Reel	12

Maximum Ratings (@ $T_A = 25^\circ\text{C}$ unless otherwise specified)

Parameter	Symbol	Value				Unit
		SOT-23	SOT-323	SOT-523	DFN1006-3	
Supply Voltage	V_{CC}	-50				V
Input Voltage	V_i	-12 to +10				V
Output Current	I_o	-100				mA
Collector Current	$I_{C(Max)}$	-100				mA
Power Dissipation	P_D	200	200	150	100	mW
Junction Temperature Range	T_J	-55 ~ +150				$^\circ\text{C}$
Storage Temperature Range	T_{STG}	-55 ~ +150				$^\circ\text{C}$



Electrical Characteristics (@ $T_A = 25^\circ\text{C}$ unless otherwise specified)

Parameter	Symbol	Test Condition	Min.	Typ.	Max.	Unit
Input Voltage	$V_{I(OFF)}$	$V_{CC} = -5V, I_O = -100\mu A$	-0.5	-	-	V
Input Voltage	$V_{I(ON)}$	$V_O = -0.3V, I_O = -20mA$	-	-	-3	V
Output Voltage	$V_{O(on)}$	$I_O = -10mA, I_I = -0.5mA$	-	-	-0.3	V
Input Current	I_I	$V_I = -5V$	-	-	-3.8	mA
Output Current	$I_{O(off)}$	$V_{CC} = -50V, V_I = 0V$	-	-	-0.5	μA
DC Current Gain	G_I	$V_O = -5V, I_O = -20mA$	20	-	-	-
Input Resistor	R_1		1.54	2.2	2.86	k Ω
Resistance ratio	R_2/R_1		0.8	1.0	1.2	-
Gain-Bandwidth Product	f_T	$V_{CE} = -10V, I_E = -5mA$ $f = 100MHz$	-	250	-	MHz



Ratings and Characteristic Curves (@ $T_A = 25^\circ\text{C}$ unless otherwise specified)

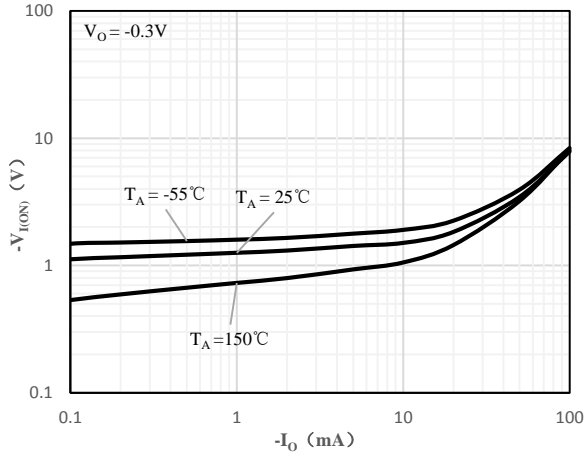

Fig 1 Input Voltage vs Output Current

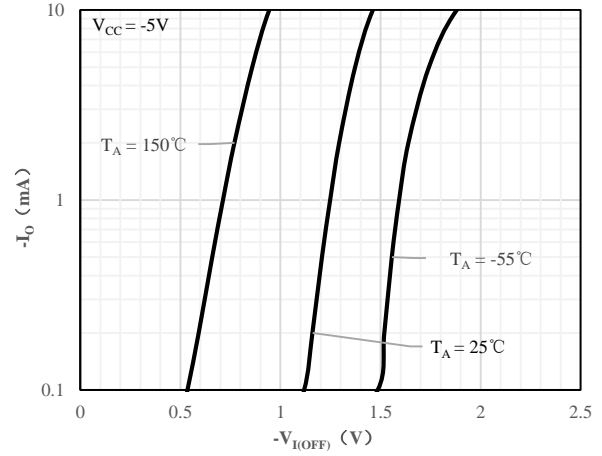

Fig 2 Output Current vs Input Voltage

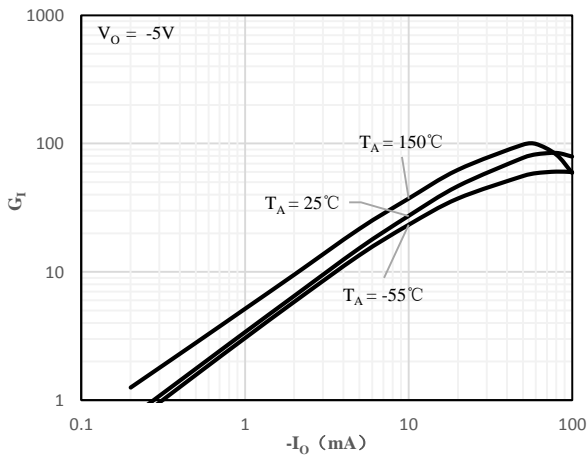

Fig 3 DC Current Gain vs Output Current

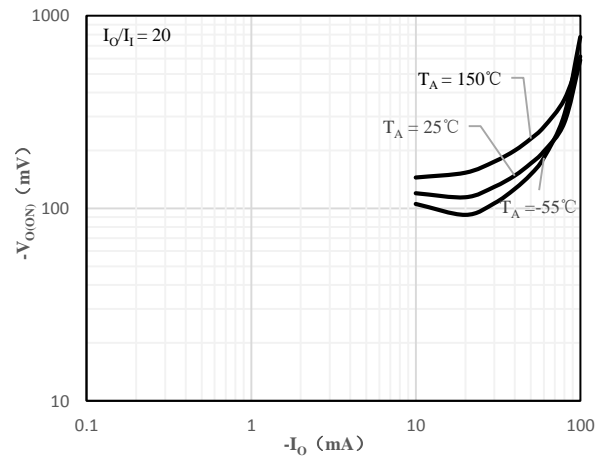
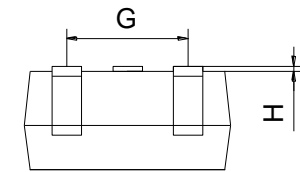
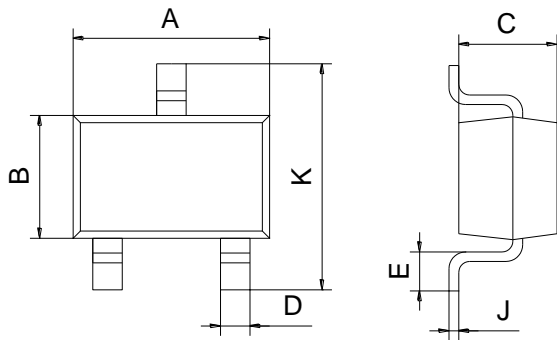
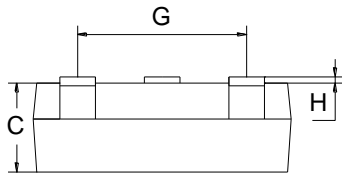
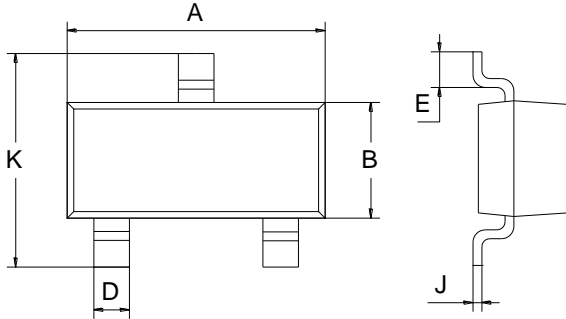

Fig 4 Output Voltage vs Output Current



Package Outline Dimensions (Unit: mm)



SOT-23		
Dimension	Min.	Max.
A	2.70	3.10
B	1.10	1.50
C	0.90	1.10
D	0.30	0.50
E	0.35	0.48
G	1.80	2.00
H	0.02	0.10
J	0.05	0.15
K	2.20	2.60

SOT-323		
Dimension	Min.	Max.
A	2.00	2.20
B	1.15	1.35
C	0.90	1.10
D	0.15	0.35
E	0.25	0.40
G	1.20	1.40
H	0.02	0.10
J	0.05	0.15
K	2.20	2.40

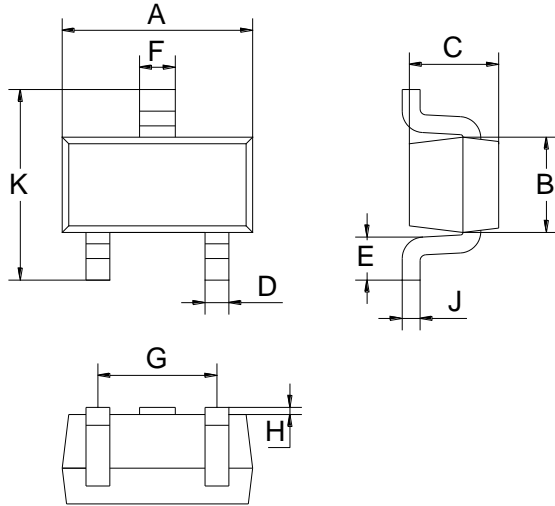

SOT-523		
Dimension	Min.	Max.
A	1.50	1.70
B	0.75	0.85
C	0.60	0.80
D	0.15	0.30
E	0.30	0.40
F	0.25	0.40
G	0.90	1.10
H	0.02	0.10
J	0.08	0.18
K	1.45	1.75

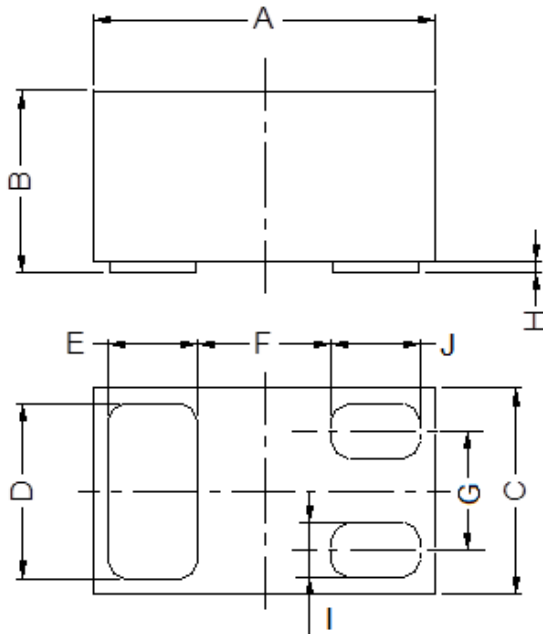

DFN1006-3			
Dimension	Min.	Typ.	Max.
A	0.95	1.00	1.075
B	0.47	0.50	0.53
C	0.55	0.60	0.675
D	0.45	0.50	0.55
E/J	0.20	0.25	0.30
F	-	0.40	-
G	-	0.35	-
H	0	0.03	0.05
I	0.10	0.15	0.20



Mounting Pad Layout (Unit: mm)

SOT-23

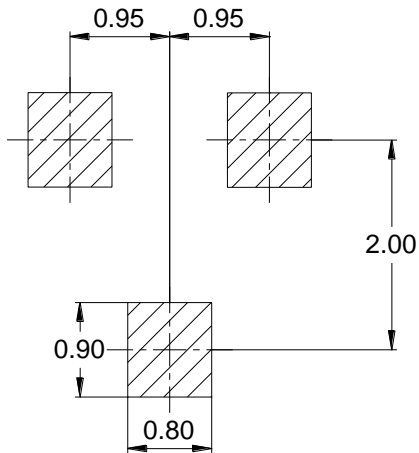

DFN1006-3

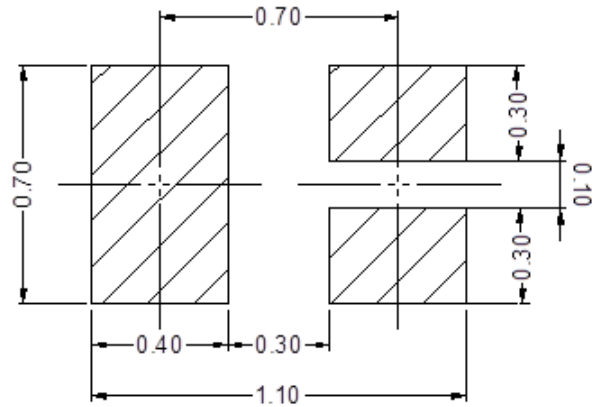

SOT-323

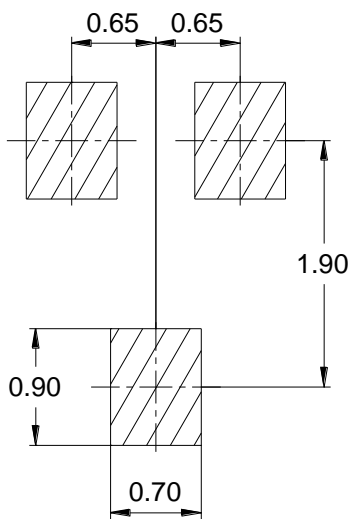

SOT-523

