



Features

- Both the DTA114E and DTC114E transistors are built-in a package
- Transistor elements are independent, eliminating interference
- Mounting cost and area can be cut in half

Mechanical Data

- Case: SOT-563
- Molding Compound: UL Flammability Classification Rating 94V-0
- Terminals: Matte tin-plated leads; solderability-per MIL-STD-202, Method 208

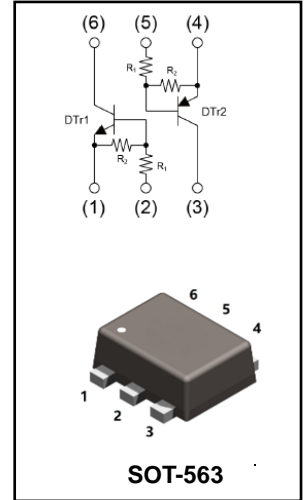

Ordering Information

Part Number	Package	Shipping Quantity	Marking Code
EMD3	SOT-563	3000 pcs / Tape & Reel	D3

Maximum Ratings (@ T_A = 25°C unless otherwise specified)

Parameter	Symbol	Value		Unit
		DTr1	DTr2	
Supply Voltage	V _{CC}	50	-50	V
Input Voltage	V _I	-10 ~ +40	10 ~ -40	V
Output Current	I _O	50	-50	mA
Collector Current	I _{C(Max)}	100	-100	mA

Thermal Characteristics

Parameter	Symbol	Value	Unit
Power Dissipation	P _D	150	mW
Thermal Resistance Junction-to-Air	R _{θJA}	833	°C/W
Operating Junction Temperature Range	T _J	-55 ~ +150	°C
Storage Temperature Range	T _{STG}	-55 ~ +150	°C



Electrical Characteristics-DTr1 (@ T_A = 25°C unless otherwise specified)

Parameter	Symbol	Test Condition	Min.	Typ.	Max.	Unit
Input Voltage	V _{I(OFF)}	V _{CC} = 5V, I _O = 100μA	0.5	-	-	V
Input Voltage	V _{I(ON)}	V _O = 0.3V, I _O = 10mA	-	-	3	V
Output Voltage	V _{O(on)}	I _O = 10mA, I _I = 0.5mA	-	-	0.3	V
Input Current	I _I	V _I = 5V	-	-	0.88	mA
Output Current	I _{O(off)}	V _{CC} = 50V, V _I = 0V	-	-	0.5	μA
DC Current Gain	G _I	V _O = 5V, I _O = 5mA	30	-	-	-
Input Resistor	R ₁ (R ₂)		7	10	13	kΩ
Resistance ratio	R ₂ /R ₁		0.8	1	1.2	-
Gain-Bandwidth Product	f _T	V _{CE} = 10V, I _E = 5mA f = 100MHz	-	250	-	MHz

Electrical Characteristics-DTr2 (@ T_A = 25°C unless otherwise specified)

Parameter	Symbol	Test Condition	Min.	Typ.	Max.	Unit
Input Voltage	V _{I(OFF)}	V _{CC} = -5V, I _O = -100μA	-0.5	-	-	V
Input Voltage	V _{I(ON)}	V _O = -0.3V, I _O = -10mA	-	-	-3	V
Output Voltage	V _{O(on)}	I _O = -10mA, I _I = -0.5mA	-	-	-0.3	V
Input Current	I _I	V _I = -5V	-	-	-0.88	mA
Output Current	I _{O(off)}	V _{CC} = -50V, V _I = 0V	-	-	-0.5	μA
DC Current Gain	G _I	V _O = -5V, I _O = -5mA	30	-	-	-
Input Resistor	R ₁ (R ₂)		7	10	13	kΩ
Resistance ratio	R ₂ /R ₁		0.8	1	1.2	-
Gain-Bandwidth Product	f _T	V _{CE} = -10V, I _E = -5mA f = 100MHz	-	250	-	MHz



Ratings and Characteristics Curves-DTr1 (@ $T_A = 25^\circ\text{C}$ unless otherwise specified)

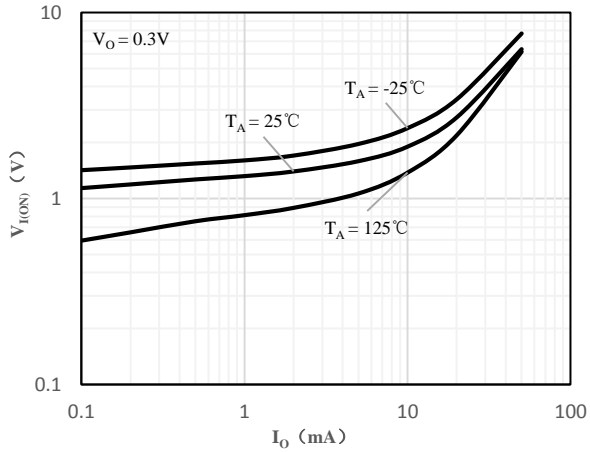

Fig 1 Input Voltage vs Output Current

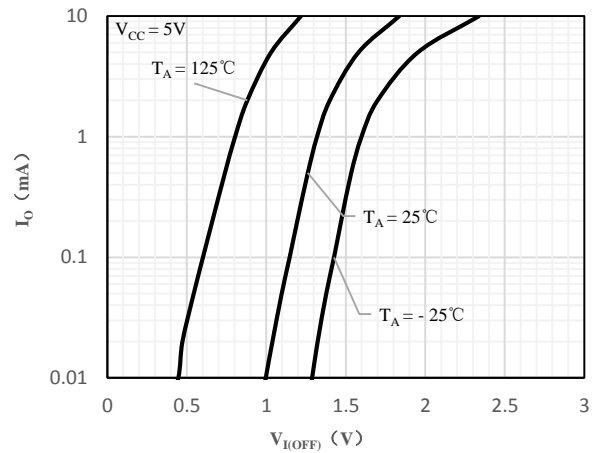

Fig 2 Output Current vs Input Voltage

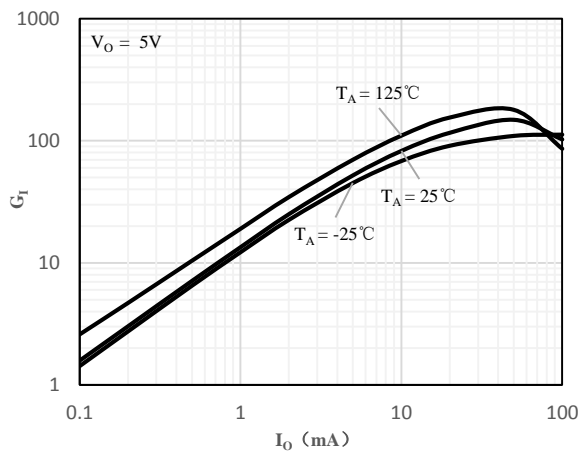

Fig 3 DC Current Gain vs Output Current

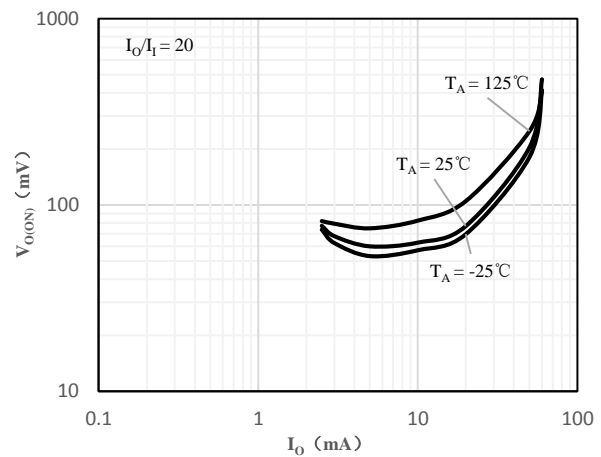

Fig 4 Output Voltage vs Output Current



Ratings and Characteristics Curves- DTr2 (@ $T_A = 25^\circ\text{C}$ unless otherwise specified)

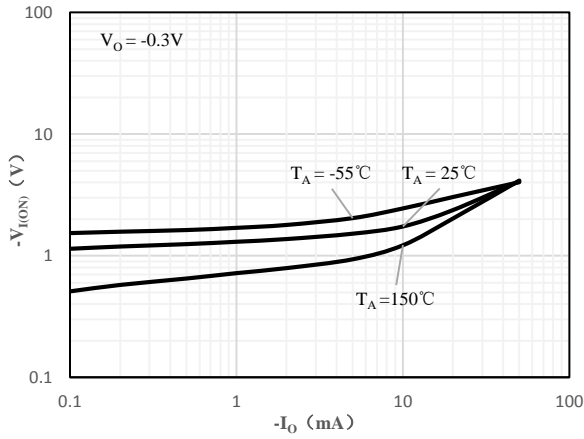

Fig 1 Input Voltage vs Output Current

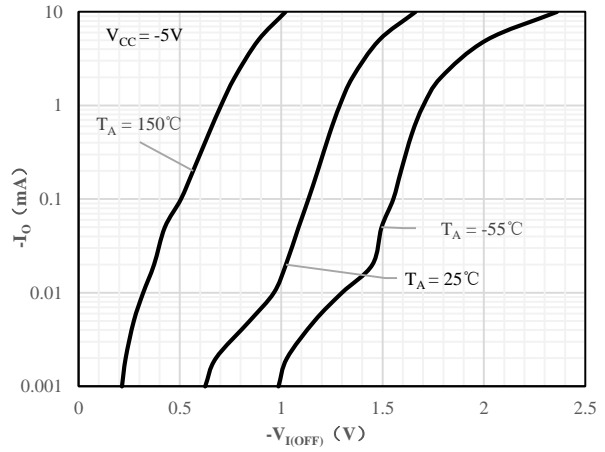

Fig 2 Output Current vs Input Voltage

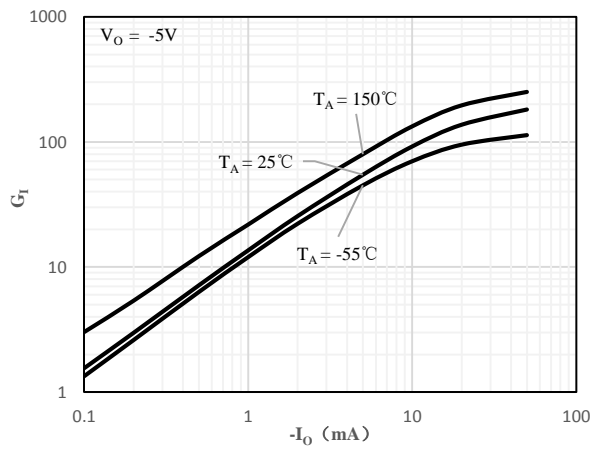

Fig 3 DC Current Gain vs Output Current

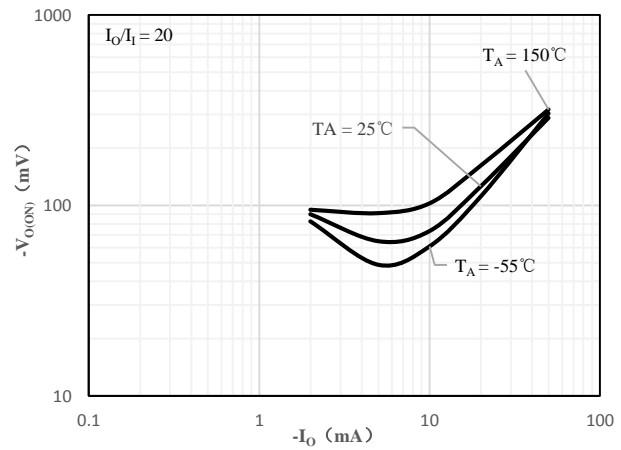
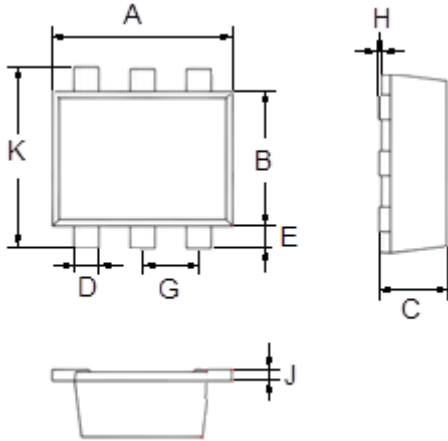

Fig 4 Output Voltage vs Output Current



Package Outline Dimensions (Unit: mm)



SOT-563		
Dimension	Min.	Max.
A	1.500	1.700
B	1.100	1.300
C	0.525	0.600
D	0.170	0.270
E	0.100	0.300
G	0.450	0.550
H	0.000	0.050
J	0.090	0.160
K	1.500	1.700

Package Outline Dimensions (Unit: mm)

SOT-563

