



Features

- Low on-resistance
- Low input capacitance
- Fast switching speed
- HBM: JESD22-A114-B: 2

Typical Applications

- DC-DC converters
- Power management functions
- Battery operated systems and solid-state relays
- Drivers: Relays, Solenoids, Lamps, Hammers, Displays, Memories, Transistors, etc.

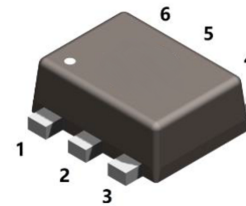
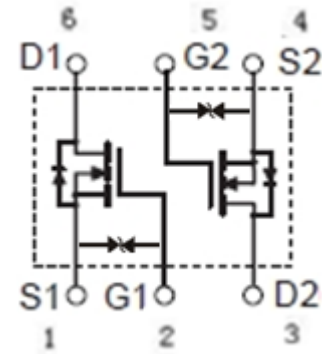

SOT-563

Mechanical Data

- Case: SOT-563
- Molding Compound: UL Flammability Classification Rating 94V-0
- Terminals: Matte Tin-Plated Leads, Solderability-per MIL-STD-202, Method 208

Ordering Information

Part Number	Package	Shipping Quantity	Marking Code
BSS138ESV	SOT-563	3000 pcs / Tape & Reel	MM5

Maximum Ratings (@ T_A = 25°C unless otherwise specified)

Parameter	Symbol	Value	Unit
Drain-to-Source Voltage	V _{DSS}	50	V
Gate-to-Source Voltage	V _{GSS}	±20	V
Continuous Drain Current (T _A = 25°C) ^{*1}	I _D	360	mA
Continuous Drain Current (T _A = 70°C) ^{*1}		290	mA
Pulsed Drain Current (t _p = 10μs, T _A = 25°C)	I _{DM}	1500	mA
Single Pulse Avalanche Energy ^{*3}	E _{AS}	0.2	mJ
Power Dissipation (T _A = 25°C) ^{*1}	P _D	250	mW
Operating Junction Temperature Range	T _J	-55 ~ +150	°C
Storage Temperature Range	T _{STG}	-55 ~ +150	°C

Thermal Characteristics

Parameter	Symbol	Min.	Typ.	Max.	Unit
Thermal Resistance Junction-to-Air ^{*1}	R _{θJA}	-	-	500	°C/W



Electrical Characteristics (@ T_A = 25°C unless otherwise specified)

Symbol	Parameter	Test Condition	Min.	Typ.	Max.	Unit
Static Characteristics						
V _{DSS}	Drain-Source Breakdown Voltage	V _{GS} = 0V, I _D = 250μA	50	-	-	V
I _{DSS}	Zero Gate Voltage Drain Current	V _{DS} = 50V, V _{GS} = 0V	-	-	1	μA
I _{GSS}	Gate-Body Leakage Current	V _{GS} = ±20V, V _{DS} = 0V	-	-	±10	μA
On Characteristics						
R _{DS(ON)}	Drain-Source On-resistance *2	V _{GS} = 10V, I _D = 0.5A	-	1	1.6	Ω
		V _{GS} = 4.5V, I _D = 0.2A	-	1.2	2.5	
		V _{GS} = 2.5V, I _D = 0.1A	-	1.7	4.5	
V _{GS(TH)}	Static Drain-Source On-resistance	V _{DS} = V _{GS} , I _D = 250μA	0.8	1	1.5	V
R _G	Gate Resistance	V _{GS} = 0V, f = 1MHz	-	48	-	Ω
Dynamic Characteristics						
C _{ISS}	Input Capacitance	V _{GS} = 0V V _{DS} = 25V f = 1.0MHz	-	32	-	pF
C _{OSS}	Output Capacitance		-	6	-	
C _{RSS}	Reverse Transfer Capacitance		-	3	-	
Switching Characteristics						
t _{d(on)}	Turn-on Delay Time *4	V _{DD} = 25V, I _D = 0.36A V _{GS} = 10V, R _G = 6Ω	-	2.2	-	ns
t _r	Turn-on Rise Time *4		-	19.2	-	
t _{d(off)}	Turn-Off Delay Time *4		-	6.2	-	
t _f	Turn-Off Fall Time *4		-	23	-	
Q _G	Total Gate-Charge	V _{DS} = 25V V _{GS} = 10V I _D = 0.2A	-	4	-	nC
Q _{GS}	Gate to Source Charge		-	0.5	-	
Q _{GD}	Gate to Drain (Miller) Charge		-	0.4	-	
Source-Drain Diode Characteristics						
V _{SD}	Diode Forward Voltage *2	I _S = 0.5A, V _{GS} = 0V	-	0.89	1.4	V
t _{rr}	Reverse Recovery Time	I _F = 1A, V _{GS} = 0V	-	15	-	ns
Q _{rr}	Reverse Recovery Charge	dI _F /dt = 100A/μs	-	8	-	nC

Notes:

- The data tested by surface mounted on a 1 inch² FR-4 board with 2OZ copper
- The data tested by pulsed, pulse width ≤ 300μs, duty cycle ≤ 2%
- The E_{AS} data shows Max. rating. The test condition is V_{DD} = 30V, V_{GS} = 10V, L = 0.5mH
- Guaranteed by design, not subject to production



Ratings and Characteristic Curves (@.T_A = 25°C unless otherwise specified)

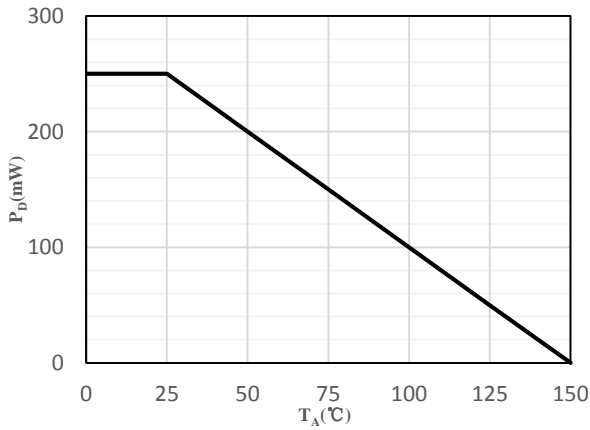

Fig 1 Power Dissipation

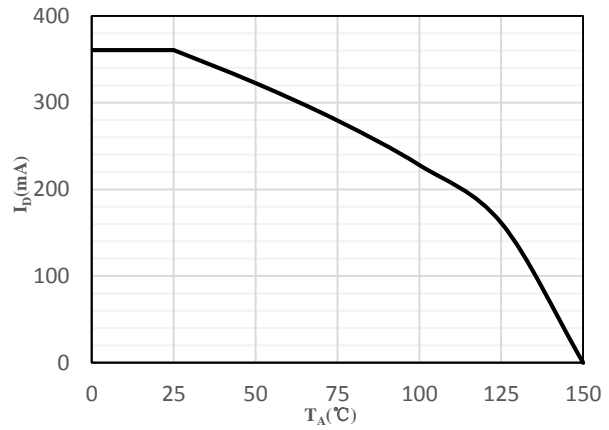

Fig 2 Drain Current

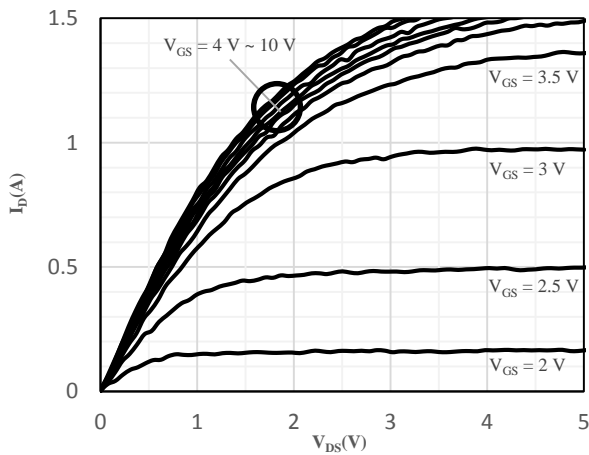

Fig 3 Typical Output Characteristics

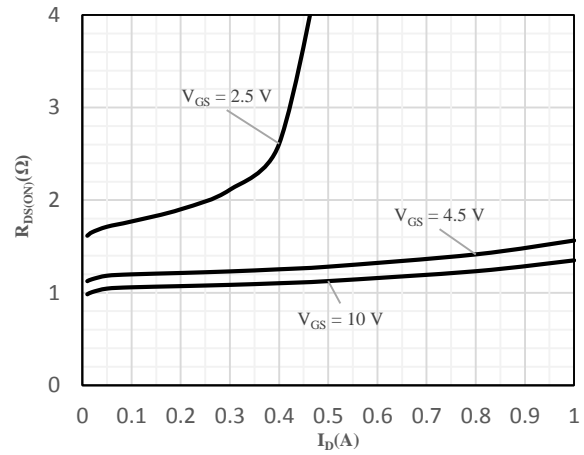

Fig 4 On-Resistance vs. Drain Current and Gate Voltage

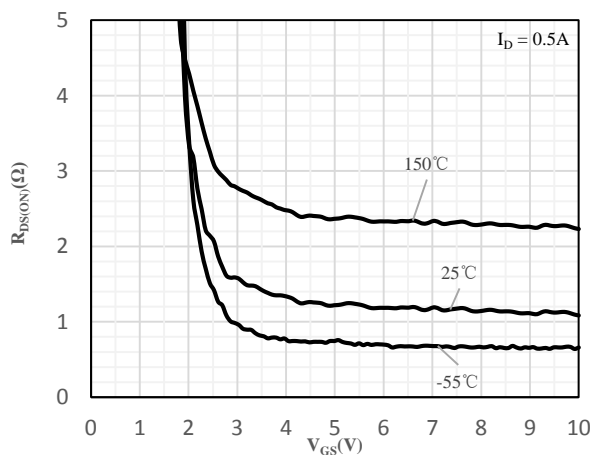

Fig 5 On-Resistance vs. Gate-Source Voltage

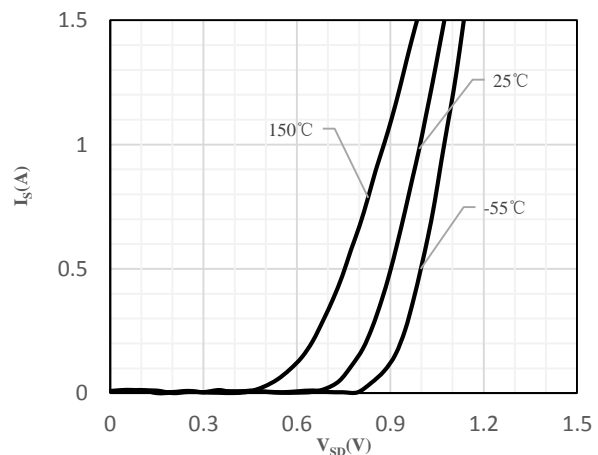

Fig 6 Body-Diode Characteristics

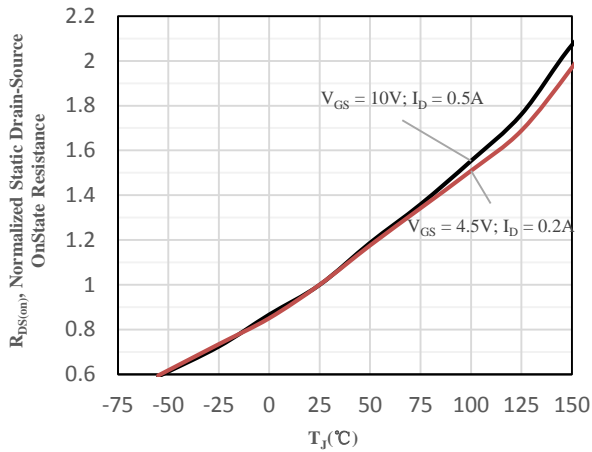

Fig 7 Normalized On-Resistance vs. Junction Temperature

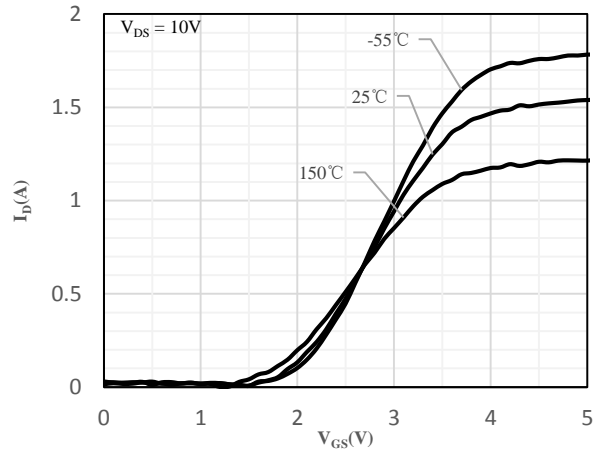

Fig 8 Transfer Characteristics

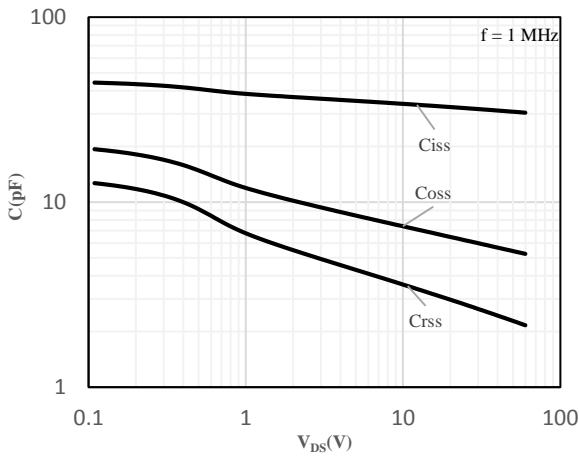

Fig 9 Capacitance Characteristics

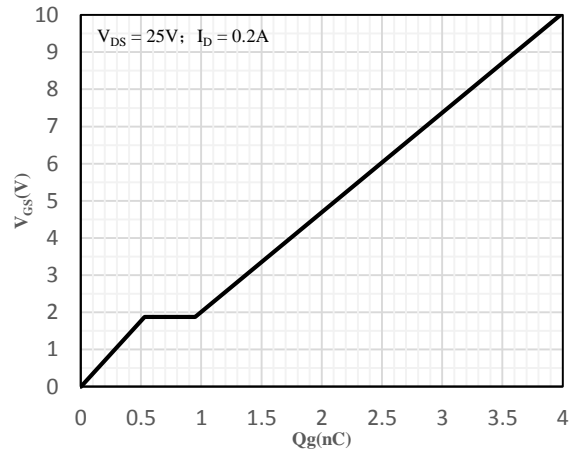

Fig 10 Gate-Charge Characteristics

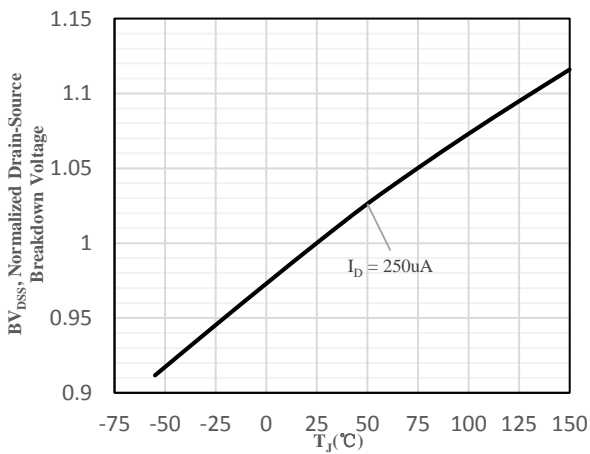

Fig 11 Normalized Breakdown Voltage vs. Junction Temperature

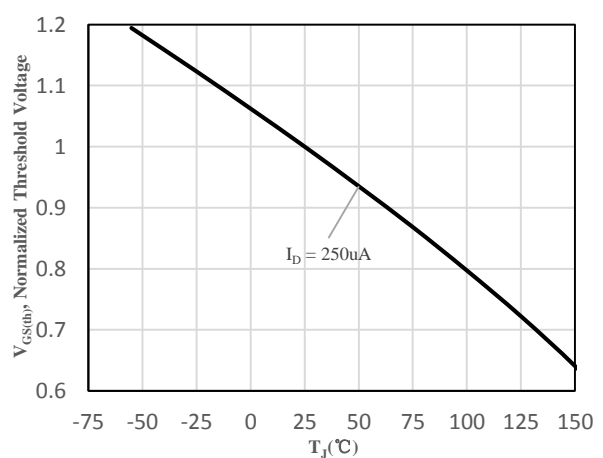
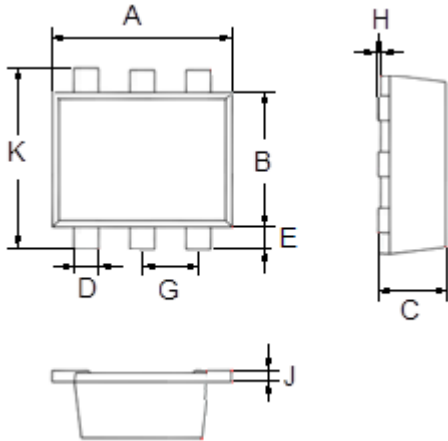

Fig 12 Normalized $V_{GS(th)}$ vs. Junction Temperature



Package Outline Dimensions (Unit: mm)



SOT-563		
Dimension	Min.	Max.
A	1.500	1.700
B	1.100	1.300
C	0.525	0.600
D	0.170	0.270
E	0.100	0.300
G	0.450	0.550
H	0.000	0.050
J	0.090	0.160
K	1.500	1.700

Mounting Pad Layout (Unit: mm)

SOT-563

