



FEATURES

Power dissipation

TO-251-3L

1. EMITTER
2. COLLECTOR
3. BASE

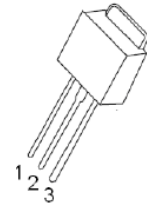

MAXIMUM RATINGS (T_a=25°C unless otherwise noted)

Symbol	Parameter	Value	Unit
V _{CBO}	Collector-Base Voltage	40	V
V _{CEO}	Collector-Emitter Voltage	30	V
V _{EBO}	Emitter-Base Voltage	6	V
I _C	Collector Current -Continuous	3	A
P _C	Collector Power Dissipation	1.25	W
T _J , T _{stg}	Operation Junction and Storage Temperature Range	-55-150	°C

Equivalent Circuit

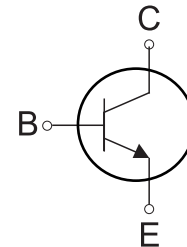

ELECTRICAL CHARACTERISTICS (T_{amb}=25°C unless otherwise specified)

Parameter	Symbol	Test conditions	Min	Typ	Max	Unit
Collector-base breakdown voltage	V(BR) _{CBO}	I _C = 100μA, I _E =0	40			V
Collector-emitter breakdown voltage	V(BR) _{CEO}	I _C = 10mA, I _B =0	30			V
Emitter-base breakdown voltage	V(BR) _{EBO}	I _E = 100μA, I _C =0	6			V
Collector cut-off current	I _{CBO}	V _{CB} = 40 V, I _E =0			1	μA
Collector cut-off current	I _{CEO}	V _{CE} = 30 V, I _B =0			10	μA
Emitter cut-off current	I _{EBO}	V _{EB} = 6 V, I _C =0			1	μA
DC current gain	h _{FE}	V _{CE} = 2 V, I _C = 1A	60		400	
Collector-emitter saturation voltage	V _{CE (sat)}	I _C = 2A, I _B = 0.2 A			0.5	V
Base-emitter saturation voltage	V _{BE (sat)}	I _C = 2A, I _B = 0.2 A			1.5	V
Transition frequency	f _T	V _{CE} = 5V, I _C =0.1A f =10MHz		90		MHz

CLASSIFICATION OF h_{FE}

Rank	R	O	Y	GR
Range	60-120	100-200	160-320	200-400



Typical Characteristics

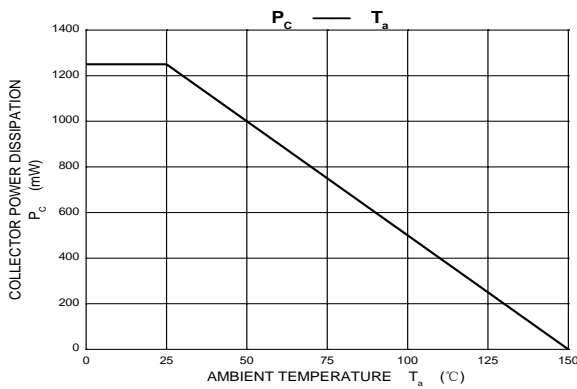
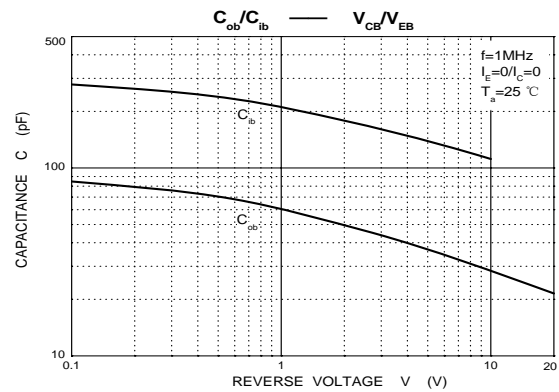
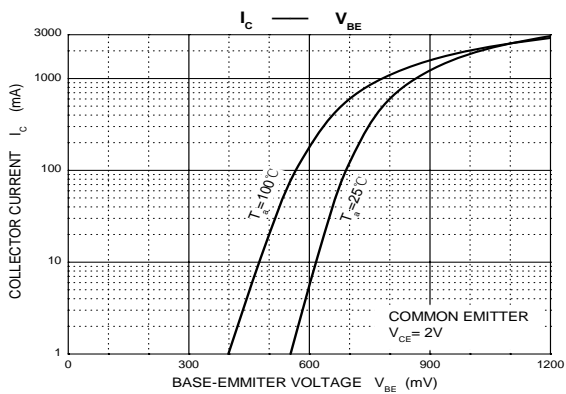
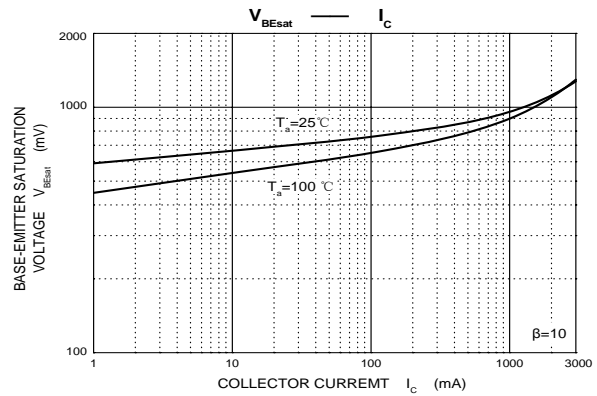
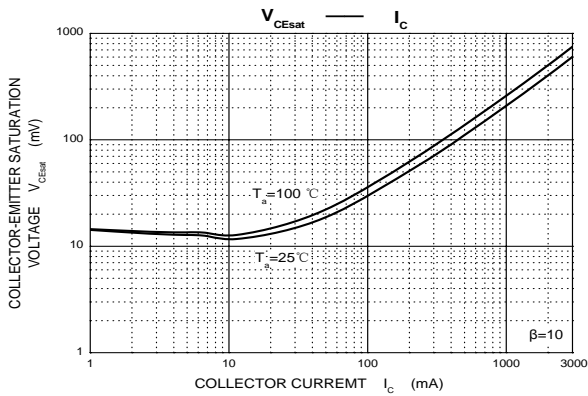
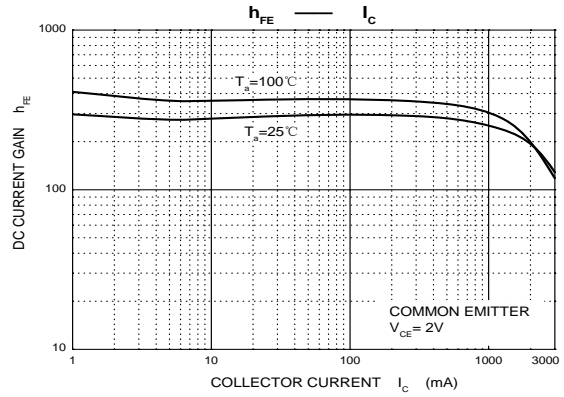
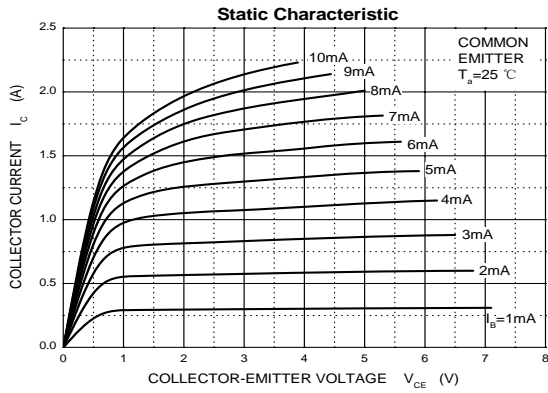



TO-251-3L Package Outline Dimensions

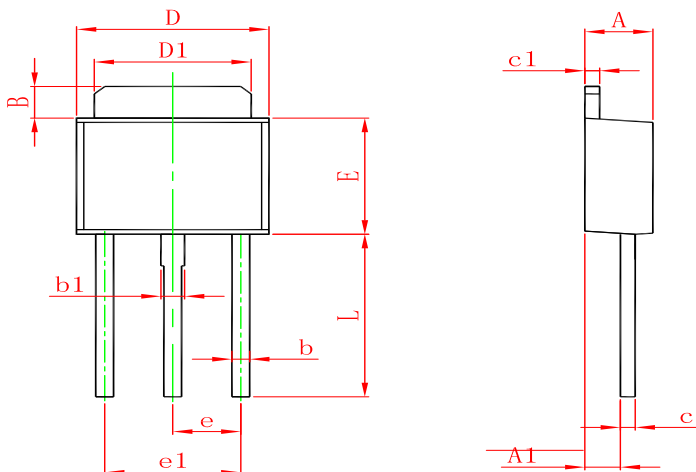

Symbol	Dimensions In Millimeters		Dimensions In Inches	
	Min.	Max.	Min.	Max.
A	2.200	2.400	0.087	0.094
A1	1.050	1.350	0.042	0.054
B	1.350	1.650	0.053	0.065
b	0.500	0.700	0.020	0.028
b1	0.700	0.900	0.028	0.035
c	0.430	0.580	0.017	0.023
c1	0.430	0.580	0.017	0.023
D	6.350	6.650	0.250	0.262
D1	5.200	5.400	0.205	0.213
E	5.400	5.700	0.213	0.224
e	2.300 TYP.		0.091 TYP.	
e1	4.500	4.700	0.177	0.185
L	7.500	7.900	0.295	0.311

Package	Packing	Quantity	Box	Box Size(mm)	Carton	Carton Size(mm)
TO-251	Bulk	500pcs/Bag	5000pcs	245×170×100	50,000pcs	525×375×270
TO-251	Tube	80pcs/Tube	4000pcs	560×178×35	40,000pcs	585×385×220