

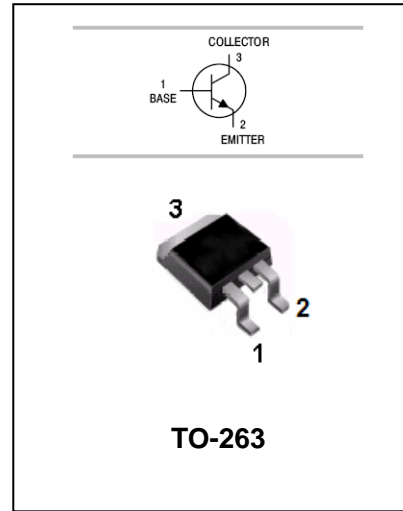

FEATURES

- Complementary to TIP32/32A/32B/32C-B



Ordering Information

Part Number	Package	Shipping	Marking Code
TIP31/31A/31B/31C-B	TO-263	50pcs / Tube or 800pcs / Tape & Reel	TIP31/31A/31B/31C

MAXIMUM RATING operating temperature range applies unless otherwise specified

Symbol	Parameter		Value	Unit
V_{CBO}	Collector-Base Voltage	TIP31-B	40	V
		TIP31A-B	60	
		TIP31B-B	80	
		TIP31C-B	100	
V_{CEO}	Collector-Emitter Voltage	TIP31-B	40	V
		TIP31A-B	60	
		TIP31B-B	80	
		TIP31C-B	100	
V_{EBO}	Emitter-Base Voltage		5	V
I_C	Collector Current	DC	3	A
		Pulse	5	
I_B	Base Current		1	A
P_C	Collector Dissipation	$T_a=25^{\circ}C$	2	W
		$T_c=25^{\circ}C$	40	
T_j, T_{stg}	Junction and Storage Temperature		-65 to +150	$^{\circ}C$



ELECTRICAL CHARACTERISTICS Ratings at 25°C ambient temperature unless otherwise specified.

Parameter	Symbol	Test conditions	MIN	TYP	MAX	UNIT
Collector-emitter Sustaining Voltage TIP31-B TIP31A-B TIP31B-B TIP31C-B	$V_{CEO(SUS)}$	$I_C=30mA, I_B=0$	40 60 80 100			V
Collector Cut-off Current TIP31/31A-B TIP31B/31C-B	I_{CEO}	$V_{CE}=30V, I_B=0$ $V_{CE}=60V, I_B=0$			0.3 0.3	mA
Collector Cut-off Current TIP31-B TIP31A-B TIP31B-B TIP31C-B	I_{CES}	$V_{CE}=40V, V_{EB}=0$ $V_{CE}=60V, V_{EB}=0$ $V_{CE}=80V, V_{EB}=0$ $V_{CE}=100V, V_{EB}=0$			200 200 200 200	μA
Emitter Cut-off Current	I_{EBO}	$V_{EB}=5V, I_C=0$			1	mA
DC Current Gain	h_{FE}	$V_{CE}=4V, I_C=1A$ $V_{CE}=4V, I_C=3A$	25 10		75	
Collector-emitter Saturation Voltage	$V_{CE(sat)}$	$I_C=3A, I_B=375mA$			1.2	V
Base-emitter Saturation Voltage	$V_{BE(sat)}$	$V_{CE}=4V, I_C=3A$			1.8	V
Transition Frequency	f_T	$V_{CE}=10V, I_C=0.5A$	3			MHz



TYPICAL CHARACTERISTICS @ Ta=25°C unless otherwise specified

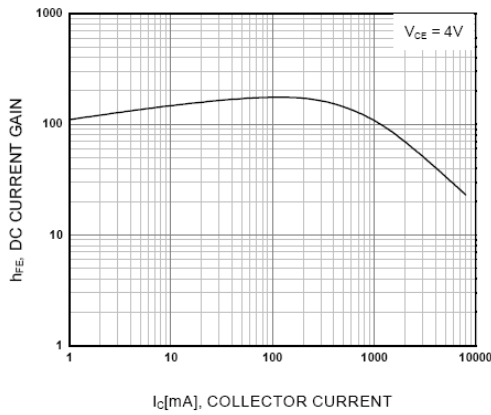

Figure 1. DC current Gain

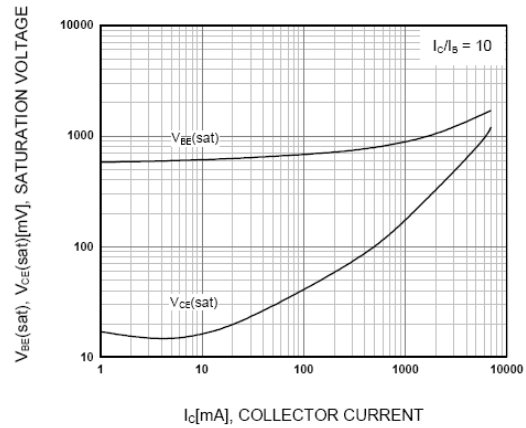

Figure 2. Base-Emitter Saturation Voltage
Collector-Emitter Saturation Voltage

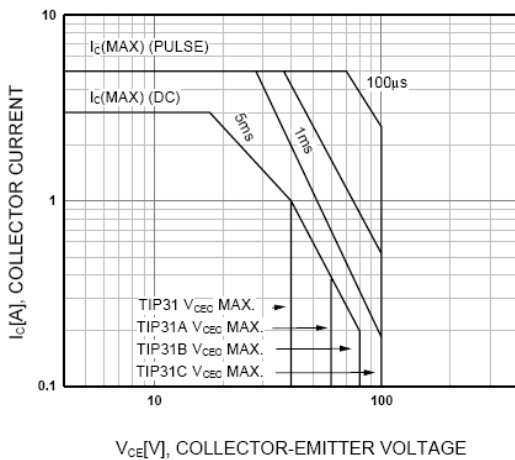

Figure 3. Safe Operating Area

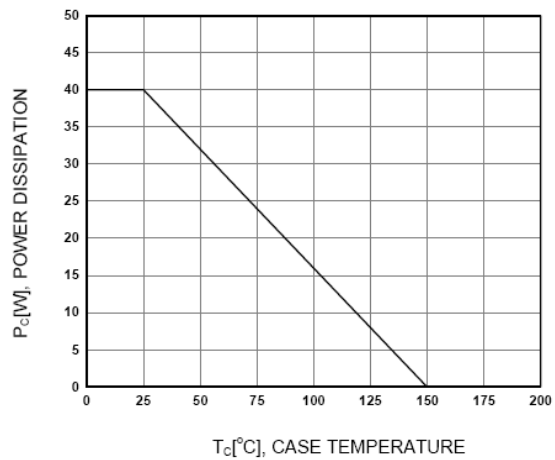

Figure 4. Power Derating



PACKAGE OUTLINE

Plastic surface mounted package

TO-263

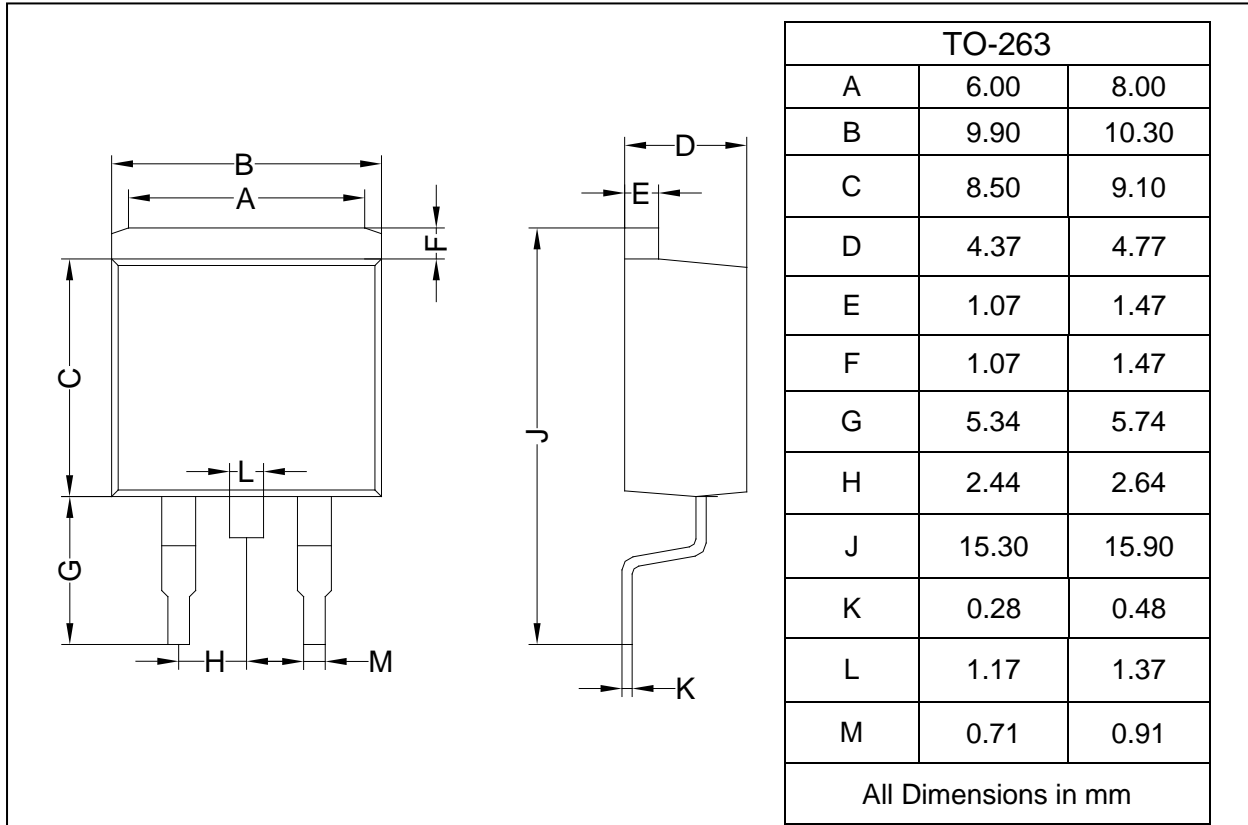

SOLDERING FOOTPRINT

Unit: mm

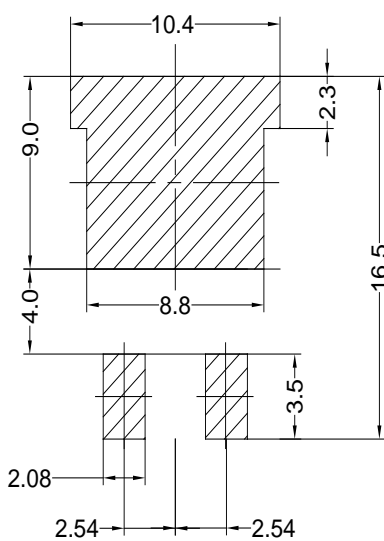

Package	Packing	Box Size LxWxH(mm)	Quantity(pcs/box)	Carton Size LxWxH(mm)	Quantity(pcs/carton)
TO-220	50pcs/Tube	560x150x50	1000	570x290x180	5000