



1. EMITTER
2. COLLECTOR
3. BASE

Features

◇ Complementary to 2SC2236 and 3 Watts output Applications.

MAXIMUM RATINGS ($T_A=25^\circ\text{C}$ unless otherwise noted)

Symbol	Parameter	Value	Units
V_{CB0}	Collector-Base Voltage	-30	V
V_{CEO}	Collector-Emitter Voltage	-30	V
V_{EBO}	Emitter-Base Voltage	-5	V
I_C	Collector Current -Continuous	-1.5	A
P_c	Collector Power Dissipation	0.9	W
T_J	Junction Temperature	150	$^\circ\text{C}$
T_{stg}	Storage Temperature	-55-150	$^\circ\text{C}$

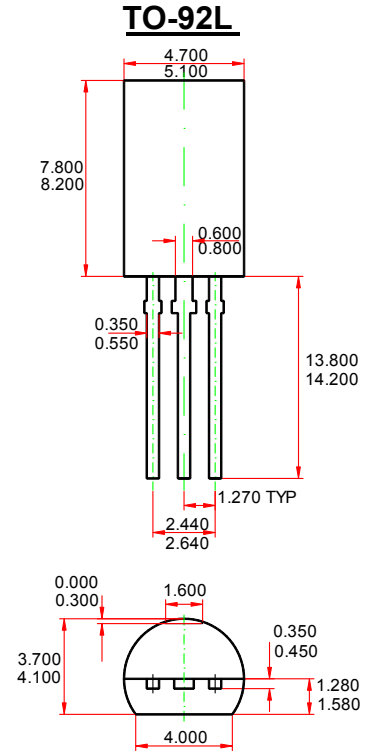

Dimensions in inches and (millimeters)

ELECTRICAL CHARACTERISTICS ($T_{amb}=25^\circ\text{C}$ unless otherwise specified)

Parameter	Symbol	Test conditions	MIN	TYP	MAX	UNIT
Collector-base breakdown voltage	$V(BR)_{CB0}$	$I_C = -1\text{mA}, I_E = 0$	-30			V
Collector-emitter breakdown voltage	$V(BR)_{CEO}$	$I_C = -10\text{mA}, I_B = 0$	-30			V
Emitter-base breakdown voltage	$V(BR)_{EBO}$	$I_E = -1\text{mA}, I_C = 0$	-5			V
Collector cut-off current	I_{CB0}	$V_{CB} = -30\text{V}, I_E = 0$			-0.1	μA
Emitter cut-off current	I_{EBO}	$V_{EB} = -5\text{V}, I_C = 0$			-0.1	μA
DC current gain	h_{FE}	$V_{CE} = -2\text{V}, I_C = -500\text{mA}$	100		320	
Collector-emitter saturation voltage	$V_{CE(sat)}$	$I_C = -1.5\text{A}, I_B = -0.03\text{A}$			-2	V
Base-emitter voltage	V_{BE}	$I_C = -500\text{mA}, V_{CE} = -2\text{V}$			-1	V
Transition frequency	f_T	$V_{CE} = -2\text{V}, I_C = -500\text{mA}$		120		MHz
Collector output capacitance	C_{ob}	$V_{CB} = -10\text{V}, I_E = 0, f = 1\text{MHz}$			30	pF

CLASSIFICATION OF h_{FE}

Rank	O	Y
Range	100-200	160-320

Typical Characteristics

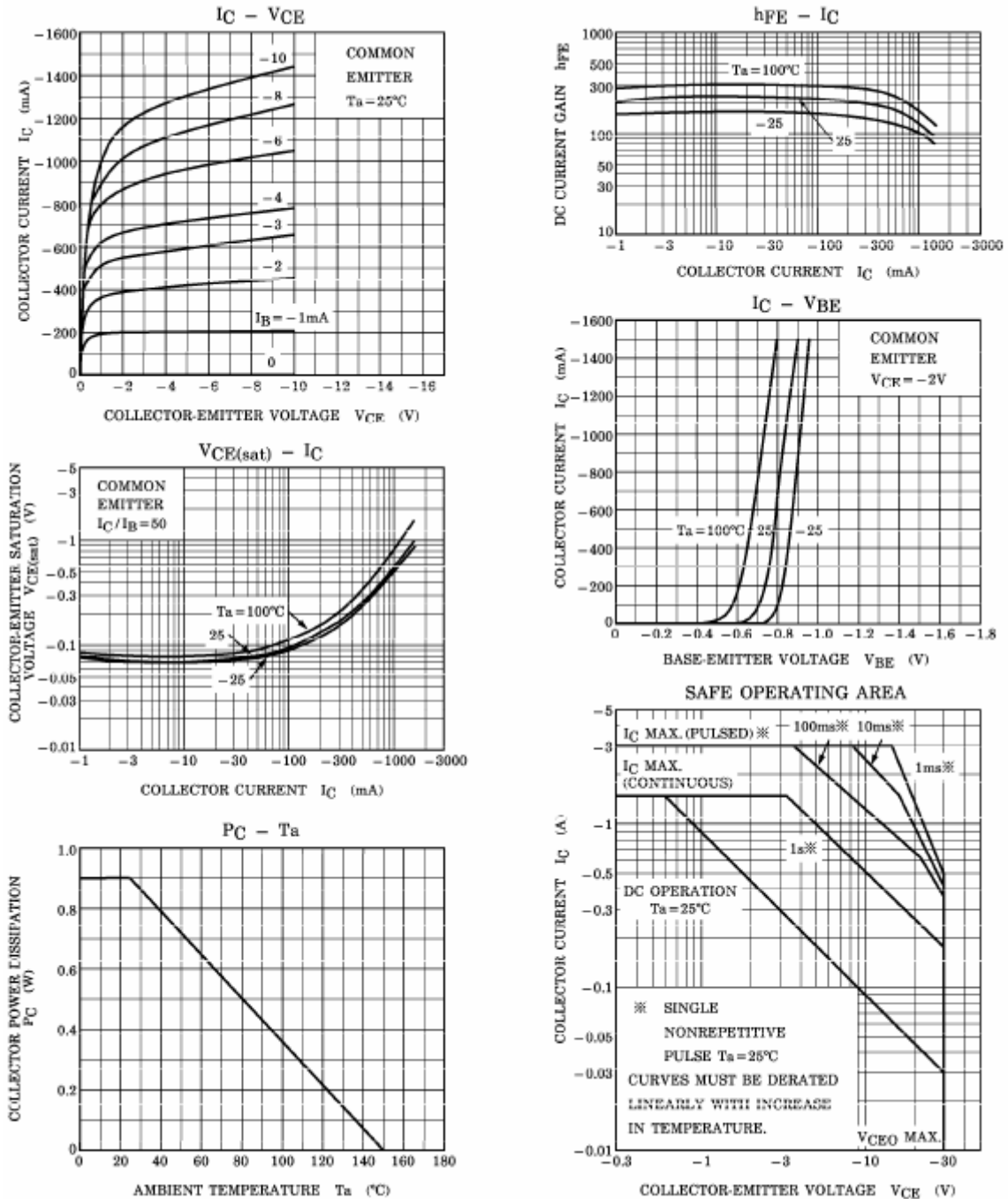

Package	Packing	Quantity	Box	Box Size(mm)	Carton	Carton Size(mm)
TO-92L	Bulk	500pcs/Bag	5000pcs	245×170×100	50,000pcs	525×375×270
TO-92L	Tape	2000pcs/Tap	2000pcs	333×203×42	20,000pcs	493×400×264