



SMAF

FEATURES

- ✧ For surface mount applications
- ✧ Easy pick and place
- ✧ Ultra fast recovery times for high efficiency
- ✧ Low forward voltage, low power loss
- ✧ Built-in strain relief, ideal for automated placement
- ✧ High temperature soldering: 250°C/10 seconds on terminals
- ✧ Plastic package has underwriters laboratories flammability classification 94V-0

MECHANICAL DATA

- ✧ Case: JEDEC SMAFL, molded plastic body over passivated chip
- ✧ Terminals: Solder Plated, solderable per MIL-STD-750, Method 2026
- ✧ Polarity: Color band denotes cathode end

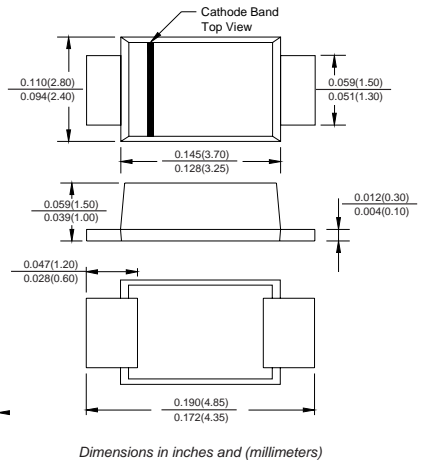

Maximum Ratings (@TA = 25°C unless otherwise specified)

Parameter	Symbol	US2AAF	US2BAF	US2DAF	US2GAF	US2JAF	US2KAF	US2MAF	UNITS
Marking code		US2A	US2B	US2D	US2G	US2J	US2K	US2M	
Maximum recurrent peak reverse voltage	V_{RRM}	50	100	200	400	600	800	1000	V
Maximum RMS voltage	V_{RWS}	35	70	140	280	420	560	700	V
Maximum DC blocking voltage	V_{DC}	50	100	200	400	600	800	1000	V
Maximum average forward rectified current at $T_J=90^\circ\text{C}$	$I_{F(AV)}$	2.0							A
Peak forward surge current 8.3ms single half sine-wave super imposed on rated load	I_{FSM}	50							A

Thermal Characteristics

Characteristic	Symbol	US2AAF	US2BAF	US2DAF	US2GAF	US2JAF	US2KAF	US2MAF	UNITS
Typical junction capacitance at 4.0V, 1MHz	C_J	50				30			pF
Maximum thermal resistance (NOTE1)	$R_{\theta JA}$	40							°C/W
	$R_{\theta JL}$	15							
Operating temperature range	T_J	-55----- +150							°C
Storage temperature range	T_{STG}	-55----- +150							°C

Electrical Characteristics (@TA = 25°C unless otherwise specified)

Characteristic	Symbol	US2AAF	US2BAF	US2DAF	US2GAF	US2JAF	US2KAF	US2MAF	UNITS	
Maximum instantaneous forward voltage at 2.0A	V_F	1.0			1.30	1.7			V	
Maximum DC reverse current @ $T_A=25^\circ\text{C}$ at rated DC blocking voltage @ $T_A=125^\circ\text{C}$	I_R	10.0				350				μA
		50				75				
Maximum reverse recovery time at $I_F=0.5\text{A}$ $I_R=1.0\text{A}$ $I_{rr}=0.25\text{A}$	t_{rr}	50				75				ns

NOTE: 1.P.C.B.mounted on 0.2X0.2"(5.0X5.0mm) copper pad area



FIG.1 – FORWARD CURRENT DERATING CURVE

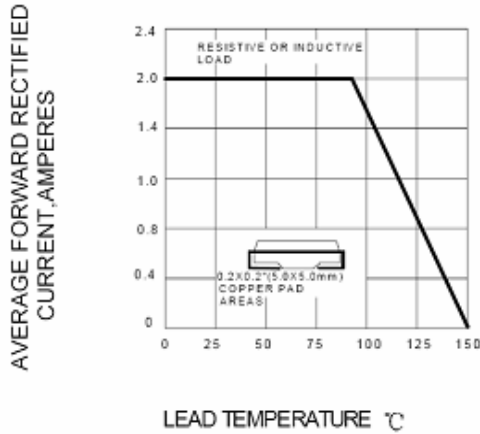

FIG.2 – MAXIMUM NON-REPETITIVE PEAK FORWARD SURGE CURRENT

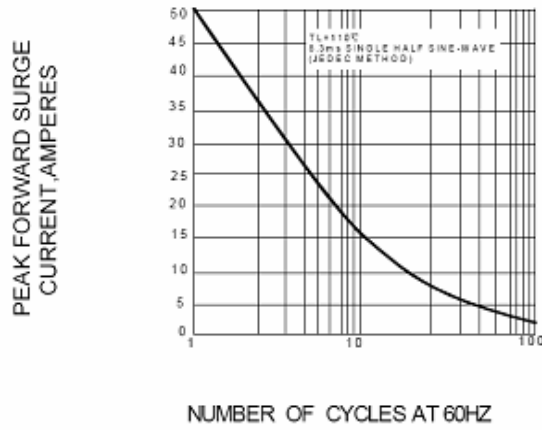

FIG.3 – TYPICAL INSTANTANEOUS FORWARD CHARACTERISTICS

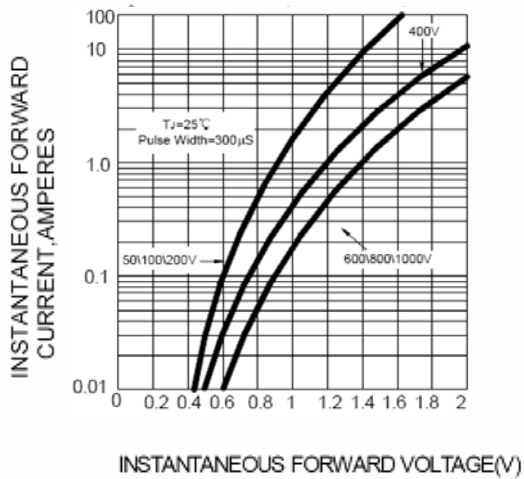

FIG.4 – TYPICAL REVERSE CHARACTERISTICS

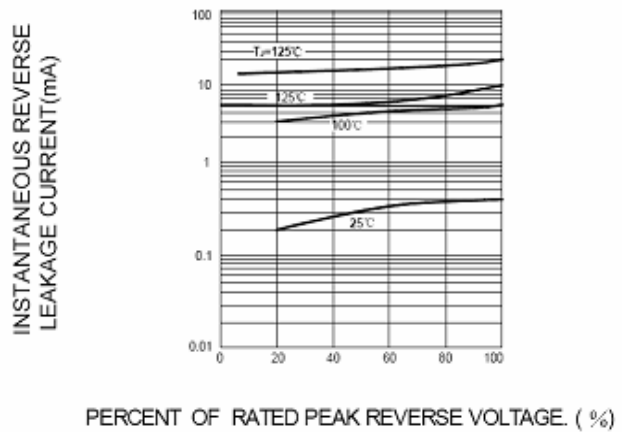

FIG.5 – TYPICAL JUNCTION CAPACITANCE

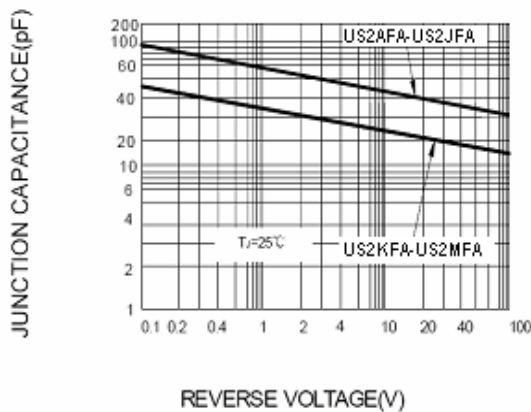
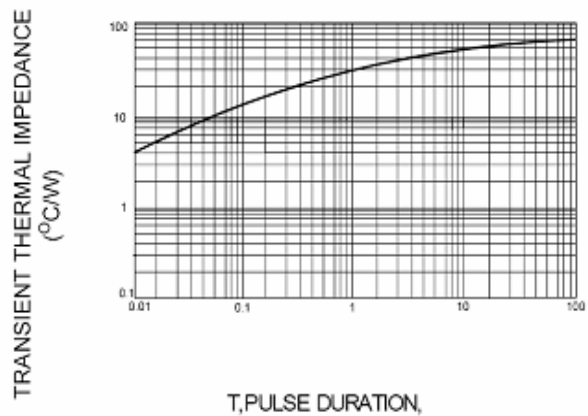

FIG.6 – TYPICAL TRANSIENT THERMAL IMPEDANCE



PACKAGE	SPQ/PCS	CARTON SPQ/PCS	CARTON SIZE/CM	CARTON GW/KG	CARTON NW/KG
SMA	5000/REEL	80000	36X30.6X31	12.00	11.00