



Reverse Voltage: 150Volts
 Forward Current:10.0Amperes

Features

- ◇ Trench Schottky Barrier technology
- ◇ Ultra low forward voltage drop
- ◇ Low power loss,high efficiency
- ◇ Excellent low reverse leakages
- ◇ Excellent high temperature stability
- ◇ High current capability
- ◇ High forward surge capability
- ◇ Lead free finish ,Rohs and WEEE compliant.

Applications

- ◇ Switching diode
- ◇ Switching mode power supply(SMPS)
- ◇ DC/DC converter
- ◇ LED lighting
- ◇ Adapter for notebook and game station

Mechanical Data

- ◇ Moisture Sensitivity: MSL Level 1,per J-STD-020
- ◇ Terminals:Matte Tin Finish.
Solderable per MIL-STD-202 Method 208
- ◇ Case Material: Molded Plastic;
Molding compound meet UL Flammability Classification Rating 94V-0
- ◇ Case:JEDEC TO-220AB,ITO-220AB,TO-252,TO-263

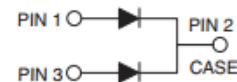
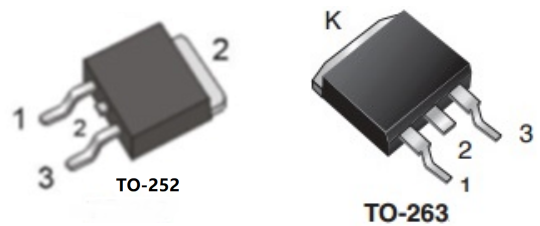
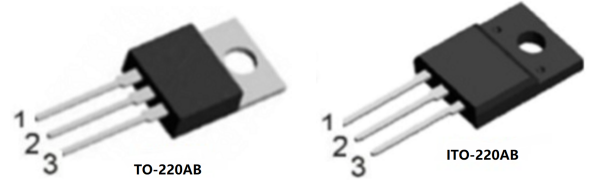

MAXIMUM RATING

Ratings at 25°C ambient temperature unless otherwise specified.

PARAMETER	SYMBOL	VALUE	UNITS
Maximum repetitive peak reverse voltage	V_{RRM}	150	V
Maximum RMS voltage	V_{RWS}	105	V
Maximum DC blocking voltage	V_{DC}	150	V
Maximum average forward rectified current	$I_{F(AV)}$	10 5	A
Peak forward surge current 8.3ms half-sine-wave	I_{FSM}	150	A
I^2t Rating for Fusing($t < 8.3ms$)	I^2t	93.375	A ² s
Typical Thermal Resistance	TO-220AB	$R_{\theta JA}$	12.0 °C/W
		$R_{\theta JC}$	2.5 °C/W
		$R_{\theta JL}$	3.0 °C/W
	ITO-220AB	$R_{\theta JC}$	4.5 °C/W
	TO-252	$R_{\theta JC}$	2.5 °C/W
TO-263	$R_{\theta JC}$	2.5 °C/W	
Typical junction capacitance: $V_R=4.0v, f=1MHz$	CJ	500	pF
Junction temperature	T_J	150	°C
Storage temperature range	TSTG	-55~150	°C



ELELTRICAL CHARACTERISTICS

PARAMETER	TEST CONDITIONS	SYMBOL	VALUE			UNITS	
			Min	Typ	Max		
Breakdown voltage per diode(min)	IR=0.5mA	V_{BR}	150	-	-	V	
Instantaneous forward voltage	IF=5A per leg	TA= 25°C	VF	-	0.80	0.85	V
		TA= 100°C	VF	-	0.75	-	V
		TA= 125°C	VF	-	0.72	-	V
	IF=3A per leg	TA= 25°C	VF	-	0.77	—	V
		TA= 100°C	VF	-	0.67	-	V
		TA= 125°C	VF	-	0.63	-	V
	IF=1A per leg	TA= 25°C	VF	-	0.62	-	V
		TA= 100°C	VF	-	0.60	-	V
		TA= 125°C	VF	-	0.58	-	V
Maximum DC reverse current @Rated DC Blocking Vlotage	TA= 25°C	IR	-	10.0	50	μ A	
	TA=125°C	IR	-	-	20000	μ A	

ODERING PACK INFORMATION

Part No.	Packge	Packing	Quatity(pcs/box)	Quatity(pcs/carton)
MBR10150LCT	TO-220	50pcs/Tube	1000	5000
MBRF10150LCT	ITO-220	50pcs/Tube	1000	5000
MBRD10150LCT	TO-252	80pcs/Tube	4000	40000
MBRD10150LCT	TO-252	2500pcs/Reel	2500	12500/25000
MBRB10150LCT	TO-263	50pcs/Tube	1000	5000/10000
MBRB10150LCT	TO-263	800pcs/Reel	800	4000/8000



RATING AND CHARACTERISTICS CURVES

FIG.1-FORWARD CURRENT DERATING CURVE

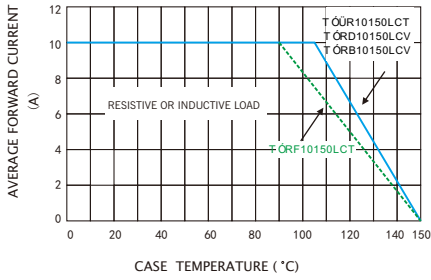

FIG.2-MAXIMUM NON-REPETITIVE PEAK FORWARD SURGE CURRENT

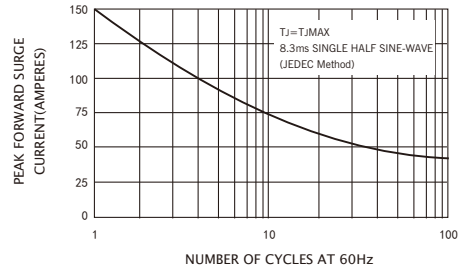

FIG.3-TYPICAL INSTANTANEOUS FORWARD CHARACTERISTICS

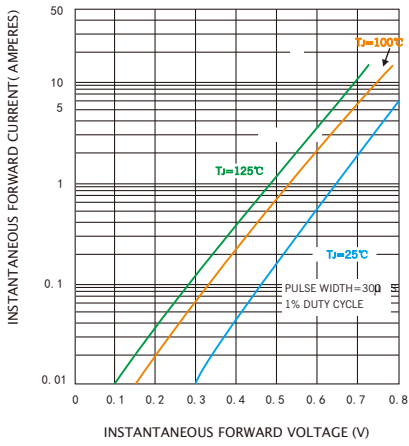

FIG.4-TYPICAL REVERSE CHARACTERISTICS

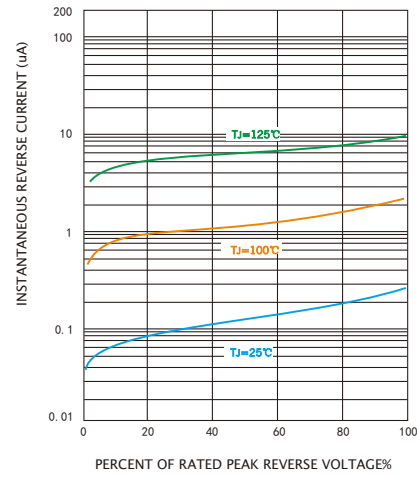
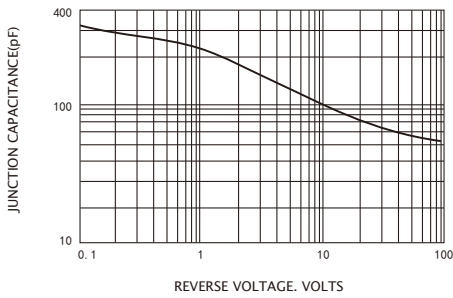

FIG.5-TYPICAL JUNCTION CAPACITANCE





PACKAGE OUTLINE DIMENSIONS

Dimensions in inches and (millimeters)

TO-220AB

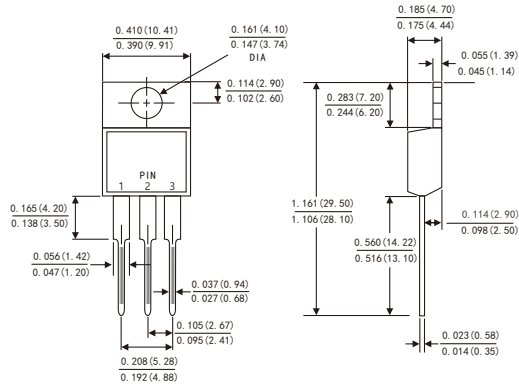

ITO-220AB

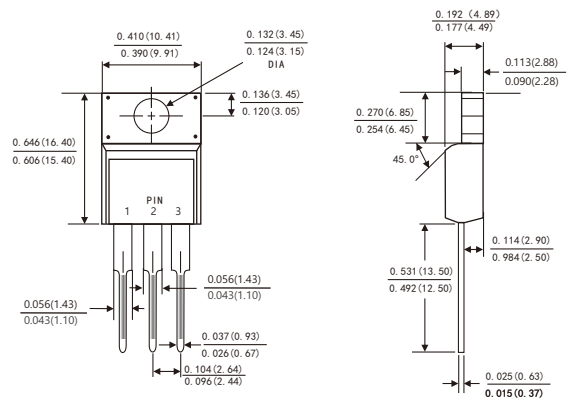

TO-263

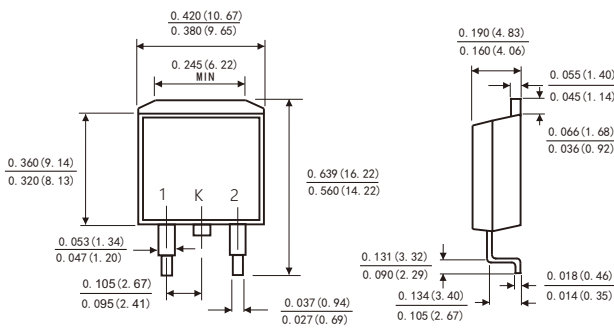

TO-252

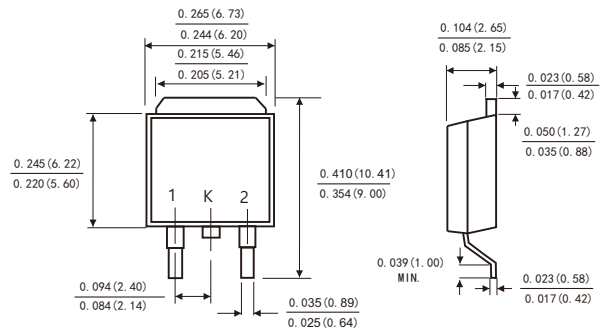

Suggested Pad Layout (TO-263)

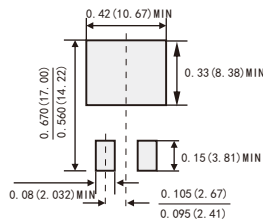

Suggested Pad Layout (TO-252)

